

ICC-ES Evaluation Report

ESR-4414

Reissued March 2025

This report also contains:

Subject to renewal March 2026

- [City of LA Supplement](#)
- [CA Supplement w/ DSA and OSHPD](#)
- [FL Supplement w/ HVHZ](#)

ICC-ES Evaluation Reports are not to be construed as representing aesthetics or any other attributes not specifically addressed, nor are they to be construed as an endorsement of the subject of the report or a recommendation for its use. There is no warranty by ICC Evaluation Service, LLC, express or implied, as to any finding or other matter in this report, or as to any product covered by the report.

Copyright © 2025 ICC Evaluation Service, LLC. All rights reserved.

<p>DIVISION: 03 00 00— CONCRETE</p> <p>Section: 03 16 00— Concrete Anchors</p> <p>DIVISION: 05 00 00— METALS</p> <p>Section: 05 05 19— Post-Installed Concrete Anchors</p>	<p>REPORT HOLDER:</p> <p>AEROSMITH FASTENING SYSTEMS</p>	<p>EVALUATION SUBJECT:</p> <p>AEROSMITH SURE- BOLT® EXTREME SURE-BOLT® / SURE-BOLT® MAX SCREW ANCHORS FOR USE IN CRACKED AND UNCRACKED CONCRETE</p>	
--	--	---	---

1.0 EVALUATION SCOPE

Compliance with the following codes:

- 2021, 2018, 2015, 2012 and 2009 [International Building Code® \(IBC\)](#)
- 2021, 2018, 2015, 2012 and 2009 [International Residential Code \(IRC\)](#)

Property evaluated:

- Structural

2.0 USES

The Aerosmith Sure-Bolt® Extreme / Sure-Bolt® screw anchors are used as anchorage to resist static, wind and seismic (Seismic Design Categories A through F) tension and shear loads in cracked and uncracked normal weight and lightweight concrete having a specified compressive strength, f'_c , of 2,500 psi to 8,500 psi (17.2 MPa to 58.6 MPa).

The Aerosmith Sure-Bolt® Max screw anchors are used as anchorage to resist static, wind and seismic tension and shear loads in normal weight and lightweight concrete having a specified compressive strength, f'_c , of 2,500 psi to 8,500 psi (17.2 MPa to 58.6 MPa). The 1/4 inch (6.4 mm) nominal diameter anchor is for use in uncracked concrete applications (Seismic Design Categories A and B only); the 3/8 inch (9.5 mm) and 1/2 inch (12.7 mm) nominal diameter anchors are for use in cracked and uncracked concrete applications (Design Categories A through F).

The Aerosmith Sure-Bolt® Extreme / Sure-Bolt® / Sure-Bolt® Max anchors comply with Section 1901.3 of the 2021, 2018 and 2015 IBC, Section 1909 of the 2012 IBC and Section 1912 of the 2009 IBC. The Aerosmith Sure-Bolt® Extreme / Sure-Bolt® / Sure-Bolt® Max screw anchors are an alternative to cast-in-place anchors described in Section 1901.3 of the 2021, 2018 and 2015 IBC, Section 1908 and 1909 of the 2012 IBC, and Section 1911 and 1912 of the 2009 IBC. The anchors may also be used where an engineered design is submitted in accordance with Section R301.1.3 of the IRC.

3.0 DESCRIPTION

3.1 AEROSMITH SURE-BOLT® EXTREME:

Aerosmith Sure-Bolt® Extreme screw anchors are comprised of a body with a hex washer head. The anchor is manufactured from carbon steel and is heat treated. The anchoring system is available in a variety of lengths, with nominal diameters of $\frac{3}{8}$ inch, $\frac{1}{2}$ inch, $\frac{5}{8}$ inch and $\frac{3}{4}$ inch. It has an Atlantic epoxy coating in gray or blue colors. The anchors have been tested for corrosion resistance in accordance with ASTM G85-11 Annex 5 for handling purposes (e.g. storage). A typical Sure-Bolt® Extreme screw anchor is illustrated in [Figure 3](#).

The hex head diameter is larger than the diameter of the anchor and is formed with serrations on the underside. The anchor body is formed with threads running most of the length of the anchor body. The anchor is installed in a predrilled hole with a powered impact wrench or torque wrench. The anchor threads cut into the concrete on the sides of the hole and interlock with the base material during the installation.

3.2 AEROSMITH SURE-BOLT®:

Aerosmith Sure-Bolt® screw anchors are comprised of a body with hex washer head. The anchor is manufactured from carbon steel and is heat-treated. The anchoring system is available in a variety of lengths, with nominal diameters of $\frac{3}{8}$ inch, $\frac{1}{2}$ inch, $\frac{5}{8}$ inch and $\frac{3}{4}$ inch. It has a minimum of 0.0002-inch-thick (5 μ m) zinc coating according to ASTM B633 type SC1, class III. A typical Sure-Bolt® screw anchor is illustrated in [Figure 3](#).

The hex head diameter is larger than the diameter of the anchor and is formed with serrations on the underside. The anchor body is formed with threads running most of the length of the anchor body. The anchor is installed in a predrilled hole with a powered impact wrench or torque wrench. The anchor threads cut into the concrete on the sides of the hole and interlock with the base material during the installation.

3.3 AEROSMITH SURE-BOLT® MAX:

Aerosmith Sure-Bolt® Max screw anchors are comprised of a body with a hex washer head. The anchor is manufactured from stainless steel with carbon steel on the tip. The anchoring system is available in a variety of lengths, with nominal diameters of $\frac{1}{4}$ inch (6.4 mm), $\frac{3}{8}$ inch (9.5 mm) and $\frac{1}{2}$ inch (12.7 mm). A typical Sure-Bolt® Max screw anchor is illustrated in [Figure 3](#).

The hex head diameter is larger than the diameter of the anchor and is formed with serrations on the underside. The anchor body is formed with threads running most of the length of the anchor body. The anchor is installed in a predrilled hole with a powered impact wrench or torque wrench. The anchor threads cut into the concrete on the sides of the hole and interlock with the base material during the installation.

3.4 Concrete:

Normal weight and lightweight concrete must conform to Sections 1903 and 1905 of the IBC, as applicable.

4.0 DESIGN AND INSTALLATION

4.1 Strength Design:

4.1.1 General: Design strength of anchors complying with the 2021 IBC, as well as Section R301.1.3 of the 2021 IRC must be determined in accordance with ACI 318-19 Chapter 17 and this report.

Design strength of anchors complying with the 2018 and 2015 IBC, as well as Section R301.1.3 of the 2018 and 2015 IRC must be determined in accordance with ACI 318-14 Chapter 17 and this report.

Design strength of anchors complying with the 2012 IBC, as well as Section R301.1.3 of the 2012 IRC, must be in accordance with ACI 318-11 Appendix D and this report.

Design strength of anchors complying with the 2009 IBC as well as Section R301.1.3 of the 2009 IRC must be in accordance with ACI 318-08 Appendix D and this report.

Design parameters are based on the 2021 IBC (ACI 318-19), 2018 and 2015 IBC (ACI 318-14) and the 2012 IBC (ACI 318-11) unless noted otherwise in Sections 4.1.1 through 4.1.12 of this report.

The strength design of anchors must comply with ACI 318-19 17.5.1.2, ACI 318-14 17.3.1 or ACI 318-11 D.4.1, as applicable, except as required in ACI 318-19 17.10, ACI 318-14 17.2.3 or ACI 318-11 D.3.3, as applicable. Strength reduction factors, ϕ , as given in ACI 318-19 17.5.3, ACI 318-14 17.3.3 or ACI 318-11 D.4.3, as applicable, and noted in [Table 3](#) and [Table 4](#) of this report, must be used for load combinations

calculated in accordance with Section 1605.1 of the 2021 IBC, 1605.2 of the IBC and Section 5.3 of ACI 318 (-19 and -14) or Section 9.2 of ACI 318-11, as applicable. Strength reduction factors, ϕ , as given in ACI 318-11 D.4.4 must be used for load combinations calculated in accordance with ACI 318-11 Appendix C.

The value of f'_c used in the calculations must be limited to a maximum of 8,000 psi (55.2 MPa), in accordance with ACI 318-19 17.3.1, ACI 318-14 17.2.7 or ACI 318-11 D.3.7, as applicable.

4.1.2 Requirements for Static Steel Strength in Tension, N_{sa} : The nominal static steel strength in tension must be calculated in accordance with ACI 318-19 17.6.1.2, ACI 318-14 17.4.1.2 or ACI 318-11 D.5.1.2, as applicable. The values for N_{sa} are given in [Table 3](#) and [Table 4](#) of this report. Strength reduction factors, ϕ , corresponding to brittle steel elements may be used for all Sure-Bolt® Extreme / Sure-Bolt® screw anchors as described in [Table 3](#)

Strength reduction factors, ϕ , corresponding to ductile steel elements may be used for Sure-Bolt® Max anchors, as described in [Table 4](#).

4.1.3 Requirements for Static Concrete Breakout Strength in Tension, N_{cb} and N_{cbg} : The nominal concrete breakout strength of a single anchor or group of anchors in tension, N_{cb} and N_{cbg} , respectively, must be calculated in accordance with ACI 318-19 17.6.2, ACI 318-14 17.4.2 or ACI 318-11 D.5.2, as applicable, with modifications as described in this section. The basic concrete breakout strength of a single anchor in tension, N_b , must be calculated in accordance with ACI 318-19 17.6.2.2, ACI 318-14 17.4.2.2 or ACI 318-11 D.5.2.2, as applicable, using the values of h_{ef} and k_{cr} as given in [Table 3](#) and [Table 4](#) of this report. The nominal concrete breakout strength in tension, in regions where analysis indicates no cracking in accordance with ACI 318-19 17.6.2.5.1, ACI 318-14 17.4.2.6 or ACI 318-11 D.5.2.6, as applicable, must be calculated with the value of $\psi_{c,N} = 1.0$ and using the value of k_{uncr} as given in [Table 3](#) and [Table 4](#) of this report.

4.1.4 Requirements for Static Pullout Strength in Tension, N_p : The nominal pullout strength of a single anchor, in accordance with ACI 318-19 17.6.3.1 and 17.6.3.2.1, ACI 318-14 17.4.3.1 and 17.4.3.2 or ACI 318-11 D.5.3.1 and D.5.3.2, as applicable, in cracked and uncracked concrete, $N_{p,cr}$ and $N_{p,uncr}$, respectively, is given in [Table 3](#) and [Table 4](#) of this report. In lieu of ACI 318-19 17.6.3.3, ACI 318-14 17.4.3.6 or ACI 318-11 D.5.3.6, as applicable, $\psi_{c,P} = 1.0$ for all design cases. In accordance with ACI 318-19 17.6.3, ACI 318-14 17.4.3.2 or ACI 318-11 D.5.3.2, as applicable, the nominal pullout strength in cracked concrete must be adjusted by calculation according to the following equation:

$$N_{p,frc} = N_{p,cr} \left(\frac{f'_c}{2,500} \right)^n \quad (\text{lb, psi}) \quad (\text{Eq-1})$$

$$N_{p,frc} = N_{p,cr} \left(\frac{f'_c}{17.2} \right)^n \quad (\text{N, MPa})$$

In regions where analysis indicates no cracking in accordance with ACI 318-19 17.6.3.3, ACI 318-14 17.4.3.6 or ACI 318-11 D.5.3.6, as applicable, the nominal pullout strength in tension must be calculated according to the following equation:

$$N_{p,frc} = N_{p,uncr} \left(\frac{f'_c}{2,500} \right)^n \quad (\text{lb, psi}) \quad (\text{Eq-2})$$

$$N_{p,frc} = N_{p,uncr} \left(\frac{f'_c}{17.2} \right)^n \quad (\text{N, MPa})$$

n = normalization exponent given in [Table 3](#) and [Table 4](#).

Where values for $N_{p,cr}$ or $N_{p,uncr}$ are not provided in [Table 3](#) and [Table 4](#), the pullout strength in tension need not be evaluated.

4.1.5 Requirements for Static Steel Strength in Shear, V_{sa} : The nominal steel strength in shear, V_{sa} , in accordance with ACI 318-19 17.7.1.2, ACI 318-14 17.5.1.2 or ACI 318-11 D.6.1.2, as applicable, is given in [Table 3](#) and [Table 4](#) of this report and must be used in lieu of the value derived by calculation from ACI 318-19 17.7.1.2b, ACI 318-14 Eq 17.5.1.2b or ACI 318-11 Eq D-29, as applicable. Strength reduction factors, ϕ , corresponding to brittle steel elements may be used for the Sure-Bolt® Extreme / Sure-Bolt® screw anchors, as described in [Table 3](#).

Strength reduction factors, ϕ , corresponding to ductile steel elements may be used for Sure-Bolt® Max anchors, as described in [Table 4](#).

4.1.6 Requirements for Static Concrete Breakout Strength in Shear, V_{cb} or V_{cbg} : The nominal concrete breakout strength in shear of a single anchor or group of anchors, V_{cb} or V_{cbg} , respectively, must be calculated in accordance with ACI 318-19 17.7.2, ACI 318-14 17.5.2 or ACI 318-11 D.6.2, as applicable, with

modifications as provided in this section. The basic concrete breakout strength of a single anchor in shear, V_b , must be calculated in accordance with ACI 318-19 17.7.2.2.1, ACI 318-14 17.5.2.2 or ACI 318-11 D.6.2.2, as applicable, using values of l_e and d_o given in [Table 3](#) and [Table 4](#) of this report.

4.1.7 Requirements for Static Concrete Pryout Strength in Shear, V_{cp} or $V_{cp,g}$: The nominal static concrete pryout strength of a single anchor or group of anchors in shear, V_{cp} or $V_{cp,g}$, respectively, must be calculated in accordance with ACI 318-19 17.7.3, ACI 318-14 17.5.3 or ACI 318-11 D.6.3, as applicable, modified by using the value of k_{cp} provided in [Table 3](#) and [Table 4](#) of this report and the value of N_{cb} or $N_{cb,g}$ as calculated in accordance with Section 4.1.3 of this report.

4.1.8 Requirements for Seismic Design:

4.1.8.1 General: For load combinations including seismic, the design must be performed in accordance with ACI 318-19 17.10, ACI 318-14 17.2.3 or ACI 318-11 D.3.3, as applicable. Modifications to ACI 318-19 17.10, ACI 318-14 17.2.3 shall be applied under Section 1905.1.8 of the 2021, 2018 and 2015 IBC. For the 2012 IBC, Section 1905.1.9 shall be omitted. Modifications to ACI 318 (-08, -05) D.3.3 shall be applied under Section 1908.1.9 of the 2009 IBC, as applicable.

4.1.8.2 Seismic Tension: The nominal steel strength and the nominal concrete breakout strength for anchors in tension must be calculated in accordance with ACI 318-19 17.6.1 and 17.6.2, ACI 318-14 17.4.1 and 17.4.2 or ACI 318-11 D.5.1 and D.5.2, respectively, as applicable, as described in Sections 4.1.2 and 4.1.3 of this report. In accordance with ACI 318-19 17.6.3.2.1, ACI 318-14 17.4.3.2 or ACI 318-11 D.5.3.2, as applicable, the appropriate value for pullout strength in tension for seismic loads, $N_{p,eq}$ may be adjusted by calculation for concrete strength in accordance with Eq-1 and section 4.1.4 whereby the value of $N_{p,cr}$ must be substituted with $N_{p,eq}$.

4.1.8.3 Seismic Shear: The nominal concrete breakout strength and pryout strength for anchors in shear must be calculated according to ACI 318-19 17.7.2 and 17.7.3, ACI 318-14 17.5.2 and 17.5.3 or ACI 318-11 D.6.2 and D.6.3, respectively, as applicable, as described in Sections 4.1.6 and 4.1.7 of this report. In accordance with ACI 318-19 17.7.1.2, ACI 318-14 17.5.1.2 or ACI 318-11 D.6.1.2, as applicable, the appropriate value for nominal steel strength for seismic loads, $V_{sa,eq}$, described in [Table 3](#) and [Table 4](#), must be used in lieu of V_{sa} .

4.1.9 Requirements for Interaction of Tensile and Shear Forces: For anchors or groups of anchors that are subject to the effects of combined tensile and shear forces, the design must be performed in accordance with ACI 318-19 17.8, ACI 318-14 17.6 or ACI 318-11 D.7, as applicable.

4.1.10 Requirements for Critical Edge Distance: In applications where $c < c_{ac}$ and supplemental reinforcement to control splitting of the concrete is not present, the concrete breakout strength in tension for uncracked concrete, calculated according to ACI 318-19 17.6.2, ACI 318-14 17.4.2 or ACI 318-11 D.5.2, as applicable, must be further multiplied by factor $\psi_{cp,N}$ as given by the following equation:

$$\psi_{cp,N} = \frac{c}{c_{ac}} \quad (\text{Eq-3})$$

where the factor $\psi_{cp,N}$ need not be taken as less than $1.5h_{ef} / c_{ac}$. For all other cases, $\psi_{cp,N} = 1.0$. In lieu of ACI 318-19 17.9.5, ACI 318-14 17.7.6 or ACI 318-11 D.8.6, as applicable, values for the critical edge distance c_{ac} must be taken from [Table 1](#) and [Table 2](#) of this report.

4.1.11 Requirements for Minimum Member Thickness, Minimum Anchor Spacing and Minimum Edge Distance: In lieu of ACI 318-19 17.9.2, ACI 318-14 17.7.1 and 17.7.3 or ACI 318-11 D.8.1 and D.8.3, respectively, as applicable, values of s_{min} and c_{min} as given in [Table 1](#) and [Table 2](#) of this report must be used. In lieu of ACI 318-19 17.9.4, ACI 318-14 17.7.5 or ACI 318-11 D.8.5, as applicable, minimum member thickness h_{min} as given in [Table 1](#) and [Table 2](#) of this report must be used.

4.1.12 Lightweight Concrete: For the use of anchors in lightweight concrete, the modification factor λ_a equal to 0.8 λ is applied to all values of $\sqrt{f'_c}$ affecting N_n and V_n .

For ACI 318-19 (2021 IBC), ACI 318-14 (2018 and 2015 IBC), ACI 318-11 (2012 IBC) and ACI 318-08 (2009 IBC), λ shall be determined in accordance with the corresponding version of ACI 318.

4.2 Allowable Stress Design (ASD):

4.2.1 General: Design values for use with allowable stress design load combinations calculated in accordance with Section 1605.1 of the 2021 IBC or Section 1605.3 of the IBC shall be established as follows:

$$T_{allowable,ASD} = \frac{\phi N_n}{\alpha} \quad (\text{Eq-4})$$

$$V_{allowable,ASD} = \frac{\phi V_n}{\alpha} \quad (\text{Eq-5})$$

where,

$T_{allowable,ASD}$ = Allowable tension load (lbf or kN)

$V_{allowable,ASD}$ = Allowable shear load (lbf or kN)

ϕN_n = Lowest design strength of an anchor or anchor group in tension as determined in accordance with ACI 318 (-19 and -14) Chapter 17 or ACI 318 (-11 and -08) Appendix D, as applicable, and 2021, 2018 and 2015 IBC Section 1905.1.8, 2009 IBC Section 1908.1.9 and Section 4.1 of this report, as applicable (lbf or kN). For the 2012 IBC, Section 1905.1.9 shall be omitted.

ϕV_n = Lowest design strength of an anchor or anchor group in shear as determined in accordance with ACI 318 (-19 and -14) Chapter 17 or ACI 318 (-11 and -08) Appendix D, as applicable, and 2021, 2018 and 2015 IBC Section 1905.1.8, 2009 IBC Section 1908.1.9 and Section 4.1 of this report, as applicable (lbf or kN). For the 2012 IBC, Section 1905.1.9 shall be omitted.

A = Conversion factor calculated as a weighted average of the load factors for the controlling load combination. In addition, α shall include all appropriate factors to account for nonductile failure modes and required over-strength.

The requirements for member thickness, edge distance and spacing, described in this report, must apply. An example of allowable stress design values for illustrative purposes is shown in [Table 5](#).

4.2.2 Requirements for Interaction of Tensile and Shear Forces: The interaction must be calculated and consistent with ACI 318-19 17.8, ACI 318-14 17.6 or ACI 318 (-11 and -08) D.7, as applicable, as follows:

For shear loads $V_{applied} \leq 0.2V_{allowable,ASD}$, the full allowable load in tension $T_{allowable,ASD}$ may be taken.

For tension loads $T_{applied} \leq 0.2T_{allowable,ASD}$, the full allowable load in shear $V_{allowable,ASD}$ may be taken.

For all other cases:

$$\frac{T_{applied}}{T_{allowable,ASD}} + \frac{V_{applied}}{V_{allowable,ASD}} \leq 1.2 \quad (\text{Eq-6})$$

4.3 Installation:

Installation parameters are provided in [Table 1](#) and [Table 2](#) and in [Figures 1](#) and [2](#) of this report. Anchors must be installed per the manufacturer's published instructions and this report. In case of conflict, this report governs. Anchor locations must comply with this report and the plans and specifications approved by the code official. Anchors must be installed in holes drilled into concrete using carbide-tipped drill bits complying with ANSI B212.15-1994. The nominal drill diameter must be equal to the nominal diameter of the anchor. Prior to anchor installation, the hole must be cleaned in accordance with the manufacturer's published installation instructions. The minimum drilled hole depth h_{hole} is given in [Table 1](#) and [Table 2](#). The anchor must be installed into the predrilled hole using a powered impact wrench or installed with a torque wrench until the proper nominal embedment depth is obtained. The maximum impact installation wrench torque, $T_{impact,max}$, and maximum installation torque, $T_{inst,max}$ for the manual torque wrench must be in accordance with [Table 1](#) and [Table 2](#).

Sure-Bolt® Extreme / Sure-Bolt® / Sure-Bolt® Max screw anchors are permitted to be loosened by a maximum of one full turn and retightened with a torque wrench or a powered impact wrench to facilitate fixture attachment or realignment. Complete removal and reinstallation of the anchor is not allowed.

4.4 Special Inspection:

Periodic special inspection is required, in accordance with Section 1705.1.1 and Table 1705.3 of the 2021, 2018, 2015 or 2012 IBC, or section 1704.15 and Table 1704.4 of the 2009 IBC, as applicable. The special inspector must make periodic inspections during anchor installation to verify anchor type, anchor dimensions, concrete type, concrete compressive strength, hole dimensions, anchor spacing, edge distances, concrete thickness, anchor embedment, installation torque, maximum impact wrench torque rating and adherence to the manufacturer's published installation instructions. The special inspector must be present as often as required in accordance with the "statement of special inspection". Under the IBC, additional requirements as set forth in Sections 1705, 1706 and 1707 must be observed, where applicable.

5.0 CONDITIONS OF USE:

The Aerosmith Sure-Bolt® Extreme / Sure-Bolt® / Sure-Bolt® Max screw anchors described in this report comply with, or are a suitable alternative to what is specified in, those codes listed in Section 1.0 of this report, subject to the following conditions:

- 5.1 Anchor sizes, dimensions and minimum embedment depths are as set forth in the tables of this report.
- 5.2 The anchors must be installed in accordance with the manufacturer's published installation instructions and this report, in cracked and uncracked normal weight and lightweight concrete having a specified compressive strength of $f'_c = 2,500$ psi to 8,500 psi (17.2 MPa to 58.6 MPa). In case of conflict between this report and the manufacturer's instructions, this report governs.
- 5.3 The values of f'_c used for calculation purposes must not exceed 8,000 psi (55.1 MPa).
- 5.4 The concrete shall have attained its minimum design strength prior to installation of the anchors.
- 5.5 Strength design values are established in accordance with Section 4.1 of this report.
- 5.6 Allowable stress design values are established in accordance with Section 4.2 of this report.
- 5.7 Anchor spacing and edge distance as well as minimum member thickness must comply with [Table 1](#) and [Table 2](#) of this report.
- 5.8 Prior to installation, calculations and details demonstrating compliance with this report must be submitted to the code official. The calculations and details must be prepared, signed and sealed by a registered design professional where required by the statutes of the jurisdiction in which the project is to be constructed.
- 5.9 Since an ICC-ES acceptance criteria for evaluating data to determine the performance of anchors subjected to fatigue or shock load is unavailable at this time, the use of these anchors under such conditions is beyond the scope of this report.
- 5.10 Anchors may be installed in regions of concrete where cracking has occurred or where analysis indicates cracking may occur ($f_t > f_r$), subject to the conditions of this report.
- 5.11 Sure-Bolt® Extreme / Sure-Bolt® anchors may be used to resist short-term loading due to wind or seismic forces in locations designated as Seismic Design Categories A through F under the IBC, subject to the conditions of this report.
- 5.12 Sure-Bolt® Max anchors may be used to resist short-term loading due to wind or seismic forces in locations designated as Seismic Design Categories A through F (Sure-Bolt® Max ¼ inch (6.4 mm) nominal diameter anchor Seismic Design Categories A and B only), under the IBC subject to the conditions of this report.
- 5.13 Anchors are not permitted to support fire-resistance-rated construction. Where not otherwise prohibited by the code, anchors are permitted for installation in fire-resistance-rated construction provided that at least one of the following conditions is fulfilled:
 - Anchors are used to resist wind or seismic forces only.
 - Anchors that support gravity load-bearing structural elements are within a fire-resistance-rated envelope or a fire-resistance-rated membrane, are protected by approved fire-resistance-rated materials, or have been evaluated for resistance to fire exposure in accordance with recognized standards.
 - Anchors are used to support nonstructural elements.
- 5.14 Use of Sure-Bolt® Extreme / Sure-Bolt® carbon steel anchors is limited to dry, interior locations.
- 5.15 Use of Sure-Bolt® Max stainless steel anchors made of stainless steel as specified in this report are permitted for exterior exposure or damp environments.
- 5.16 Use of Sure-Bolt® Max stainless steel anchors made of stainless steel as specified in this report are permitted for contact with preservative-treated and fire-retardant-treated wood.
- 5.17 Anchors have been evaluated for reliability against brittle fracture and found not to be significantly sensitive to stress-induced hydrogen embrittlement.
- 5.18 Special inspection must be provided in accordance with Section 4.4 of this report.
- 5.19 Anchors are manufactured under an approved quality control program with inspections by ICC-ES.

6.0 EVIDENCE SUBMITTED

- 6.1 Data in accordance with the [ICC-ES Acceptance Criteria for Mechanical Anchors in Concrete Elements \(AC193\)](#), dated October 2017 (editorially revised December 2020), which incorporates requirements in ACI 355.2(-19 and -07), for use in cracked and uncracked concrete.
- 6.2 Data in accordance with ASTM G85-11 Annex 5 for corrosion resistance.
- 6.3 Quality control documentation.

7.0 IDENTIFICATION

- 7.1 The ICC-ES mark of conformity, electronic labeling, or the evaluation report number (ICC-ES ESR-4414) along with the name, registered trademark, or registered logo of the report holder must be included in the product label.
- 7.2 In addition, the anchors are identified by packaging labeled with the evaluation report holder's name (Aerosmith Fastening Systems) and address, anchor name, and anchor size. The anchors have the size (diameter x length, in inches) and letters "afs" stamped on the head of each screw anchor.
- 7.3 The report holder's contact information is the following:

AEROSMITH FASTENING SYSTEMS
5621 DIVIDEND ROAD
INDIANAPOLIS, INDIANA 46241
(317) 243-5959
www.aerosmithfastening.com
contact@aerosmithfastening.com

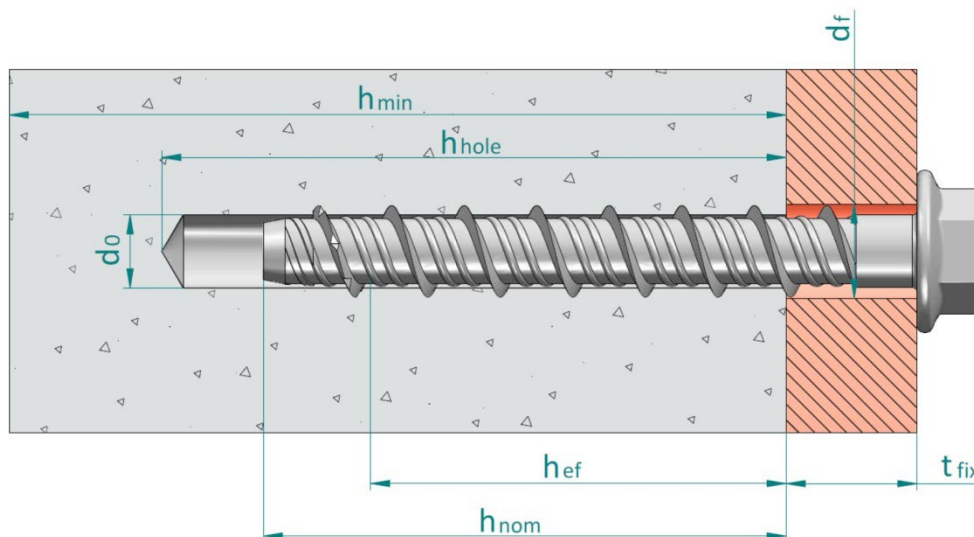

FIGURE 1—ANCHOR DIMENSIONS

TABLE 1—SURE-BOLT® EXTREME/ SURE-BOLT® ANCHOR INSTALLATION PARAMETERS¹

Characteristic	Symbol	Unit	Nominal Anchor Diameter									
			1/4"		3/8"		1/2"		5/8"		3/4"	
Drill Bit Diameter	<i>d_o</i>	in (mm)	1/4 (6.4)	1/4 (6.4)	3/8 (9.5)	3/8 (9.5)	1/2 (12.7)	1/2 (12.7)	5/8 (15.9)	5/8 (15.9)	3/4 (19.1)	3/4 (19.1)
Nominal Embedment Depth	<i>h_{nom}</i>	in (mm)	1 5/8 (41)	2 1/2 (64)	2 1/2 (64)	3 1/4 (83)	3 (76)	4 1/4 (108)	3 1/4 (83)	5 (127)	4 (102)	6 1/4 (159)
Effective Embedment Depth	<i>h_{ef}</i>	in (mm)	1.23 (31)	1.98 (50)	1.85 (47)	2.49 (63)	2.21 (56)	3.27 (83)	2.36 (60)	3.85 (98)	2.97 (75)	4.89 (124)
Minimum Hole Depth	<i>h_{hole}</i>	in (mm)	2 (51)	2 7/8 (73)	2 3/4 (70)	3 1/2 (89)	3 3/8 (86)	4 5/8 (117)	3 5/8 (92)	5 3/8 (137)	4 3/8 (111)	6 5/8 (168)
Fixture Hole Diameter	<i>d_f</i>	in (mm)	3/8 (9.5)		1/2 (12.7)		5/8 (15.9)		3/4 (19.1)		7/8 (22.2)	
Maximum Installation Torque	<i>T_{inst,max}</i>	ft.lb (Nm)	15 (20)	24 (33)	35 (47)	50 (68)	45 (61)	65 (88)	85 (115)	100 (136)	115 (156)	150 (203)
Maximum impact wrench torque rating	<i>T_{impact,max}</i>	ft lb (Nm)	150 (203)	150 (203)	380 (515)	380 (515)	380 (515)	380 (515)	380 (515)	380 (515)	380 (515)	380 (515)
Minimum Concrete Thickness	<i>h_{min}</i>	in (mm)	3 1/4 (83)	4 (102)	4 (102)	4 3/4 (121)	4 3/4 (121)	6 3/4 (171)	5 (127)	7 (178)	6 (152)	8 1/8 (206)
Critical Edge Distance	<i>c_{ac}</i>	in (mm)	2 1/2 (64)	3 (76)	4 (102)	5 (127)	4 1/2 (114)	5 (127)	3 3/4 (95)	7 (178)	4 1/2 (114)	8 (203)
Minimum Edge Distance (<i>c_{min}</i>)	<i>c_{min}</i>	in (mm)	1 1/2 (38)	2 (51)	1 1/2 (38)	1 3/8 (38)	1 3/4 (44)	1 3/4 (44)	1 3/4 (44)	1 3/4 (44)	1 3/4 (44)	1 3/4 (44)
Minimum Spacing (<i>s_{min}</i>)	<i>s_{min}</i>	in (mm)	3 (76)	3 (76)	3 (76)	3 (76)	3 (76)	3 (76)	4 (102)	4 (102)	4 (102)	4 (102)
Minimum Overall Anchor Length	<i>l_{anch}</i>	in (mm)	1 3/4 (44)	2 5/8 (67)	2 3/4 (70)	3 1/2 (89)	3 1/4 (82)	4 1/2 (114)	3 1/2 (89)	5 1/4 (133)	4 1/4 (108)	6 1/2 (165)
Torque Wrench Socket Size	-	in	7/16		9/16		3/4		15/16		1 1/8	
Maximum Fixture Thickness ²	<i>t_{fix}</i>	in (mm)	L - 1 5/8 (L-41)	L - 2 1/2 (L-64)	L - 2 1/2 (L-64)	L - 3 1/4 (L-83)	L-3 (L-76)	L-4 1/4 (L-108)	L-3 1/4 (L-83)	L-5 (L-127)	L-4 (L-102)	L-6 1/4 (L-159)

- The tabulated data is to be used in conjunction with the design criteria given in ACI 318 (-19 and-14) Chapter 17 or ACI 318-11 Appendix D, as applicable.
- L = total anchor length

TABLE 2—SURE-BOLT® MAX ANCHOR INSTALLATION PARAMETERS¹

Characteristic	Symbol	Unit	Nominal Anchor Diameter					
			1/4"		3/8"		1/2"	
Drill Bit Diameter	<i>d_o</i>	in (mm)	1/4 (6.4)	1/4 (6.4)	3/8 (9.5)	3/8 (9.5)	1/2 (12.7)	1/2 (12.7)
Nominal Embedment Depth	<i>h_{nom}</i>	in (mm)	2 (51)	3 (76)	2 3/4 (70)	4 (102)	3 (76)	5 (127)
Effective Embedment Depth	<i>h_{ef}</i>	in (mm)	1.16 (29)	2.01 (51)	1.49 (38)	2.56 (65)	1.60 (41)	3.30 (84)
Minimum Hole Depth	<i>h_{hole}</i>	in (mm)	2 3/8 (60)	3 3/8 (86)	3 (76)	4 1/4 (108)	3 3/8 (86)	5 3/8 (137)
Fixture Hole Diameter	<i>d_f</i>	in (mm)	3/8 (9.5)		1/2 (12.7)		5/8 (15.9)	
Maximum Installation Torque	<i>T_{inst,max}</i>	ft.lb (Nm)	10 (14)	10 (14)	35 (47)	35 (47)	35 (47)	35 (47)
Maximum impact wrench torque rating	<i>T_{impact,max}</i>	ft lb (Nm)	100 (136)	100 (136)	157 (213)	157 (213)	157 (213)	157 (213)
Minimum Concrete Thickness	<i>h_{min}</i>	in (mm)	3 1/4 (83)	4 (102)	4 (102)	4 3/4 (121)	4 3/4 (121)	6 3/4 (171)
Critical Edge Distance	<i>c_{ac}</i>	in (mm)	2 1/2 (64)	3 (76)	4 (102)	5 1/2 (140)	4 1/2 (114)	6 1/2 (165)
Minimum Edge Distance (<i>c_{min}</i>)	<i>c_{min}</i>	in (mm)	1 3/4 (44)	2 (51)	1 1/2 (38)	1 1/2 (38)	1 3/4 (44)	1 3/4 (44)
Minimum Spacing (<i>s_{min}</i>)	<i>s_{min}</i>	in (mm)	3 (76)	3 (76)	3 (76)	3 (76)	3 (76)	3 (76)
Minimum Overall Anchor Length	<i>l_{anch}</i>	in (mm)	2 1/8 (54)	3 1/8 (79)	3 (76)	4 1/4 (108)	3 1/4 (83)	5 1/4 (133)
Torque Wrench Socket Size	-	in	7/16		9/16		3/4	
Maximum Fixture Thickness ²	<i>t_{fix}</i>	in (mm)	L - 2 (L-51)	L - 3 (L-76)	L - 2 3/4 (L-70)	L - 4 (L-102)	L - 3 (L-76)	L - 5 (L-127)

- The tabulated data is to be used in conjunction with the design criteria given in ACI 318 (-19 and -14) Chapter 17 or ACI 318-11 Appendix D, as applicable.
- L = total anchor length

TABLE 3— SURE-BOLT® EXTREME/ SURE-BOLT® ANCHOR DESIGN INFORMATION^{1,2}

Characteristic	Symbol	Unit	Nominal Anchor Diameter										
			1/4"		3/8"		1/2"		5/8"		3/4"		
Nominal Embedment Depth	h_{nom}	in (mm)	1 5/8 (41)	2 1/2 (64)	2 1/2 (64)	3 1/4 (83)	3 (76)	4 1/4 (108)	3 1/4 (83)	5 (127)	4 (102)	6 1/4 (159)	
Anchor Category	1, 2 or 3	-	2				1						
Steel Strength in Tension and Shear													
Minimum specified ultimate strength	f_{uta}	psi (N/mm ²)	110,000 (758)		111,000 (765)		107,000 (738)		102,000 (703)		99,000 (683)		
Minimum specified yield strength	f_y	psi (N/mm ²)	88,000 (607)		88,800 (612)		85,600 (590)		81,600 (563)		79,200 (546)		
Effective stress area (screw anchor body)	A_{se}	in ² (mm ²)	0.0438 (28.3)		0.0943 (60.8)		0.1768 (114.1)		0.2703 (174.4)		0.3988 (257.3)		
Steel Strength in Tension	N_{sa}	lb (kN)	4,820 (21.4)		10,465 (46.6)		18,920 (84.1)		27,570 (122.6)		39,480 (175.6)		
Strength Reduction Factor for Steel Failure in Tension	ϕ_{sa}	-	0.65										
Steel Strength in Shear	V_{sa}	lb (kN)	1,555 (6.9)	2,740 (12.2)	4,815 (21.4)	4,850 (21.6)	7,270 (32.3)	9,370 (41.7)	10,300 (45.8)	12,735 (56.7)	14,240 (63.3)	14,240 (63.3)	
Steel Strength in Shear, Seismic	$V_{sa,eq}$	lb (kN)	1,555 (6.9)	2,495 (11.1)	4,075 (18.1)	4,075 (18.1)	5,075 (22.6)	7,140 (31.8)	8,030 (35.7)	10,300 (45.8)	12,105 (53.9)	12,105 (53.9)	
Strength Reduction Factor for Steel Failure in Shear	ϕ_{sa}	-	0.60										
Pullout Strength in Tension³													
Pullout Strength in Uncracked Concrete	$N_{p,uncr}$	lb (kN)	1,600 (7.1)	3,345 (14.9)	-	-	-	-	-	-	-	-	
Pullout Strength in Cracked Concrete	$N_{p,cr}$	lb (kN)	730 (3.3)	1,330 (5.9)	-	-	3,225 (14.3)	-	-	-	-	-	
Pullout Strength in Cracked Concrete, Seismic	$N_{p,eq}$	lb (kN)	730 (3.3)	1,330 (5.9)	-	-	3,225 (14.3)	-	-	-	-	-	
Normalization Exponent, Uncracked Concrete	n	-	0.42	0.37	-	-	0.50	-	-	-	-	-	
Normalization Exponent, Cracked Concrete	n	-	0.39	0.50	-	-	0.35	-	-	-	-	-	
Strength Reduction Factor for Pullout Strength in Tension	ϕ_p	-	0.55				0.65						
Concrete Breakout Strength in Tension													
Effective embedment	h_{ef}	in (mm)	1.23 (31)	1.98 (50)	1.85 (47)	2.49 (63)	2.21 (56)	3.27 (83)	2.36 (60)	3.85 (98)	2.97 (75)	4.89 (124)	
Effectiveness Factor for Uncracked Concrete	k_{uncr}	-	24			27			24				
Effectiveness Factor for Cracked Concrete	k_{cr}	-	17				21		17				
Strength Reduction Factor for Concrete Breakout Strength in Tension	ϕ_{cb}	-	0.55				0.65						
Axial stiffness in service load range in uncracked concrete	β_{uncr}	lb/inch (N/mm)	214,520 (37,570)	178,090 (31,190)	63,150 (11,059)	207,850 (36,400)	139,250 (24,386)	140,060 (24,528)	222,870 (39,031)	254,980 (44,653)	292,630 (51,247)	305,530 (53,506)	
Axial stiffness in service load range in cracked concrete	β_{cr}	lb/inch (N/mm)	186,270 (32,620)	178,950 (31,340)	63,150 (11,059)	174,020 (30,476)	130,385 (22,834)	140,060 (24,528)	105,130 (18,411)	192,280 (33,673)	160,050 (28,029)	165,525 (28,968)	
Concrete Breakout Strength in Shear													
Nominal Diameter	d_o^2	in (mm)	1/4 (6.4)	1/4 (6.4)	3/8 (9.5)	3/8 (9.5)	1/2 (12.7)	1/2 (12.7)	5/8 (15.9)	5/8 (15.9)	3/4 (19.1)	3/4 (19.1)	
Load Bearing Length of Anchor	l_e	in (mm)	1.23 (31)	1.98 (50)	1.85 (47)	2.49 (63)	2.21 (56)	3.27 (83)	2.36 (60)	3.85 (98)	2.97 (75)	4.89 (124)	
Reduction Factor for Concrete Breakout Strength in Shear	ϕ_{cb}	-	0.70										
Concrete Pryout Strength in Shear													
Coefficient for Pryout Strength	k_{cp}	-	1.0				2.0		1.0		2.0		
Reduction Factor for Pryout Strength in Shear	ϕ_{cp}	-	0.70										

1. The tabulated data is to be used in conjunction with the design criteria given in ACI 318(-19 and -14) Chapter 17 or ACI 318-11 Appendix D, as applicable.
 2. All values of ϕ were determined from the load combinations of Section 1605.1 of the 2021 IBC, Section 1605.2 of the 2018, 2015, 2012, or 2009 IBC, ACI 318(-19 and -14) Section 5.3 or ACI 318-11 Section 9.2, as applicable. If the load combinations of ACI 318-11 Appendix C are used, then the appropriate value of ϕ must be determined in accordance with ACI 318-11 D.4.4. For reinforcement that meets ACI 318(-19 and -14) Chapter 17 or ACI 318 Appendix D, as applicable, requirements for Condition A, see ACI 318-19 17.5.3, ACI 318-14 17.3.3 or ACI 318-11 D.4.3, as applicable, for the appropriate ϕ factor when the load combinations of Section 1605.1 of the 2021 IBC, Section 1605.2 of the 2018, 2015, 2012 or 2009 IBC, ACI 318 (-19 and -14) Section 5.3 or ACI 318-11 Section 9.2, as applicable, are used.
 3. Where no value is reported for pullout strength, this resistance does not need to be considered.

TABLE 4—SURE-BOLT® MAX ANCHOR DESIGN INFORMATION^{1,2}

Characteristic	Symbol	Unit	Nominal Anchor Diameter					
			1/4"		3/8"		1/2"	
Nominal Embedment Depth	h_{nom}	in (mm)	2 (51)	3 (76)	2 3/4 (70)	4 (102)	3 (76)	5 (127)
Anchor Category	1, 2 or 3	-	2		2	1	2	1
Steel Strength in Tension and Shear								
Minimum specified ultimate strength	f_{uta}	psi (N/mm ²)	107,328 (740)		107,328 (740)		104,427 (720)	
Minimum specified yield strength	f_y	psi (N/mm ²)	85,862 (592)		85,862 (592)		83,542 (576)	
Effective stress area (screw anchor body)	A_{se}	in ² (mm ²)	0.0398 (25.7)		0.0904 (58.3)		0.1709 (110.3)	
Steel Strength in Tension	N_{sa}	lb (kN)	4,272 (19.0)		9,702 (43.2)		17,847 (79.4)	
Strength Reduction Factor for Steel Failure in Tension	ϕ_{sa}	-	0.75					
Steel Strength in Shear	V_{sa}	lb (kN)	1,501 (6.68)	2,473 (11.00)	2,824 (12.56)	5,701 (25.36)	4,632 (20.26)	10,161 (45.20)
Steel Strength in Shear, Seismic	$V_{sa,eq}$	lb (kN)	-	-	2,824 (12.56)		4,004 (17.81)	
Strength Reduction Factor for Steel Failure in Shear	ϕ_{sa}	-	0.65					
Pullout Strength in Tension³								
Pullout Strength in Uncracked Concrete	$N_{p,uncr}$	lb (kN)	733 (3.26)	2,620 (11.65)	1,895 (8.43)	4,321 (19.22)	2,301 (10.23)	6,541 (29.10)
Pullout Strength in Cracked Concrete	$N_{p,cr}$	lb (kN)	-	-	1,247 (5.55)	-	-	4,913 (21.86)
Pullout Strength in Cracked Concrete, Seismic	$N_{p,eq}$	lb (kN)	-	-	1,247 (5.55)	-	-	4,422 (19.67)
Normalization Exponent, Uncracked Concrete	n	-	0.49	0.32	0.39	0.29	0.43	0.38
Normalization Exponent, Cracked Concrete	n	-	-	-	0.49	0.50	0.50	0.43
Strength Reduction Factor for Pullout Strength in Tension	ϕ_p	-	0.55		0.55	0.65	0.55	0.65
Concrete Breakout Strength in Tension								
Effective embedment	h_{ef}	in (mm)	1.16 (29)	2.01 (51)	1.49 (38)	2.56 (65)	1.60 (41)	3.30 (84)
Effectiveness Factor for Uncracked Concrete	k_{uncr}	-	24		24			
Effectiveness Factor for Cracked Concrete	k_{cr}	-	-		17			
Strength Reduction Factor for Concrete Breakout Strength in Tension	ϕ_{cb}	-	0.55		0.55	0.65	0.55	0.65
Axial stiffness in service load range in uncracked concrete	β_{uncr}	lb/inch (N/mm)	20,697 (3,625)	62,330 (10,916)	46,722 (8,182)	84,144 (14,736)	48,782 (8,543)	136,727 (23,944)
Axial stiffness in service load range in cracked concrete	β_{cr}	lb/inch (N/mm)	-		49,689 (8,702)	72,339 (12,669)	45,342 (7,941)	105,244 (18,431)
Concrete Breakout Strength in Shear								
Nominal Diameter	d_o^2	in (mm)	1/4 (6.4)	1/4 (6.4)	3/8 (9.5)	3/8 (9.5)	1/2 (12.7)	1/2 (12.7)
Load Bearing Length of Anchor	l_e	in (mm)	1.16 (29)	2.01 (51)	1.49 (38)	2.56 (65)	1.60 (41)	3.30 (84)
Reduction Factor for Concrete Breakout Strength in Shear	ϕ_{cb}	-	0.70					
Concrete Pryout Strength in Shear								
Coefficient for Pryout Strength	k_{cp}	-	1.0		1.0	2.0	1.0	2.0
Reduction Factor for Pryout Strength in Shear	ϕ_{cp}	-	0.70					

1. The tabulated data is to be used in conjunction with the design criteria given in ACI 318 (-19 and -14) Chapter 17 or ACI 318-11 Appendix D, as applicable.

2. All values of ϕ were determined from load combinations of Section 1605.1 of the 2021 IBC, Section 1605.2 of the 2018, 2015, 2012 or 2009 IBC, ACI 318 (-19 and -14) Section 5.3 or ACI 318-11 Section 9.2, as applicable. If the load combinations of ACI 318-11 Appendix C are used, then the appropriate value of ϕ must be determined in accordance with ACI 318-11 D.4.4. For reinforcement that meets ACI 318 (-19 and -14) Chapter 17 or ACI 318 Appendix D, as applicable, requirements for Condition A, see ACI 318-19 17.5.3, ACI 318-14 17.3.3 or ACI 318-11 D.4.3, as applicable, for the appropriate ϕ factor when the load combinations of Section 1605.1 of the 2021 IBC, Section 1605.2 of the 2018, 2015, 2012 or 2009 IBC, ACI 318 (-19 and -14) Section 5.3 or ACI 318-11 Section 9.2, as applicable, are used.

3. Where no value is reported for pullout strength, this resistance does not need to be considered.

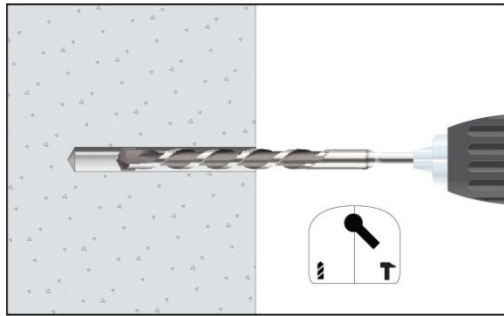

1. DRILL

Drill a hole into the base material of the correct diameter and depth using a drill bit that meets the requirements of ANSI B212.15

Caution: oversized holes in base material will reduce or eliminate the mechanical interlock of the threads with the base material and reduce the anchor's load capacity

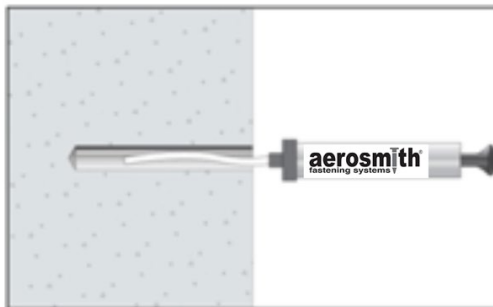

2. BLOW AND CLEAN

Remove dust and debris from hole using a hand pump, compressed air or a vacuum to remove loose particles left from drilling.

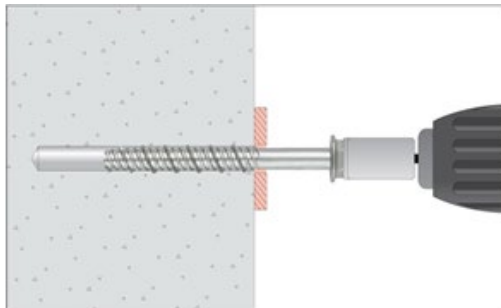

3. INSTALL

Select a powered impact wrench or a torque wrench that does not exceed the maximum torque $T_{impact,max}$ or $T_{inst,max}$ respectively. Attach an appropriate sized hex socket to the wrench. Mount the screw anchor head in the socket.

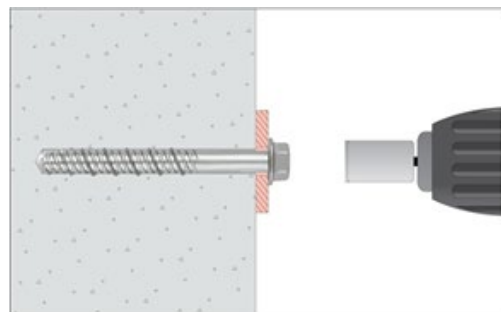

4. APPLY TORQUE

Drive the anchor with an impact driver or a torque wrench through the fixture and into the hole until the anchor head washer comes in contact with the fixture. The anchor must be snug after installation. Do not spin the hex socket off the anchor to disengage.

The screw anchors are permitted to be loosened by a maximum of one full turn and retightened with a torque wrench or a powered impact wrench to facilitate fixture attachment or realignment

FIGURE 2—MANUFACTURER’S PUBLISHED INSTALLATION INSTRUCTIONS

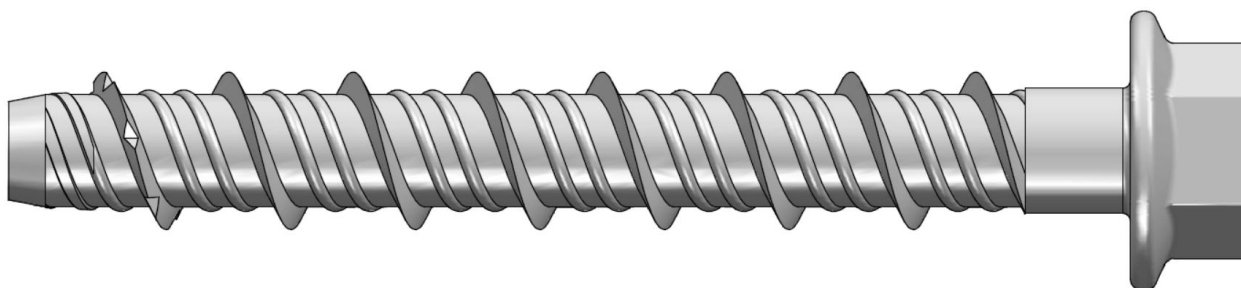

FIGURE 3—SURE-BOLT® EXTREME / SURE-BOLT® / SURE-BOLT® MAX SCREW ANCHOR

TABLE 5—EXAMPLE ALLOWABLE STRESS DESIGN VALUES FOR ILLUSTRATIVE PURPOSES^{1,2,3,4,5,6,7,8,9,10}

Nominal Anchor Diameter d_o (inch)	Nominal Embedment Depth h_{nom} (inch)	Allowable Tension Load $T_{allowable,ASD}$ (lb)
1/4	1 5/8	595
1/4	2 1/2	1,242
3/8	2 1/2	1,492
3/8	3 1/4	2,330
1/2	3	1,948
1/2	4 1/4	3,116
5/8	3 1/4	1,911
5/8	5	3,981
3/4	4	2,698
3/4	6 1/4	5,699

1. Single anchor.
2. Static tension loading only.
3. Concrete determined to remain uncracked for the life of the anchorage.
4. Load combinations taken from ACI 318(-19 and -14) Section 5.3 or ACI 318-11 Section 9.2, as applicable with no seismic loading.
5. 30% Dead Load (D) and 70% Live Load (L), controlling load combination $1.2D + 1.6L$.
6. Calculation of the weighted average for $\alpha = 1.2 \times 0.3 + 1.6 \times 0.7 = 1.48$
7. Normal weight concrete, $f'_c = 2,500$ psi.
8. $C_{a1} = C_{a2} \geq C_{ac}$
9. Concrete thickness $h \geq h_{min}$.
10. Values are for Condition B (supplementary reinforcement in accordance with ACI 318-19 17.5.3, ACI 318-14 7.3.3 or ACI 318-11 D.4.3 is not provided).

Illustrative procedure of Allowable Stress Design calculation. Method ACI 318-19, Chapter 17

Per the figure below and the following information:

- 2 anchors Sure-Bolt® Extreme 1/2" x 3-1/4" anchor length
- Concrete: strength 4,000 psi, cracked, 5 inches thick
- $h_{ef} = 2.21$ in
- Anchor Layout: as per sketch
- Static or quasi-static loads

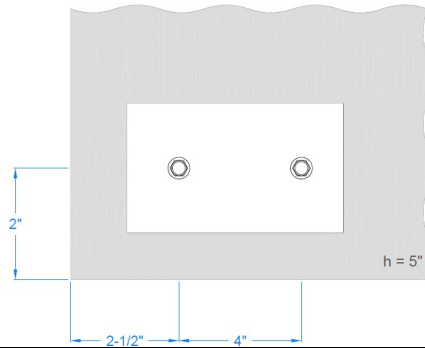

Step	ACI 318-19 Section Reference	ESR Section Reference	CALCULATIONS
1	17.9	Section 4.1.11 Table 1	Verify spacing / edge distance / member thickness $s = 4 \text{ in} > 3 \text{ in} \rightarrow \text{verified}$ $c_{a1} = 2-1/2 \text{ in} > 1-3/4 \text{ in} \rightarrow \text{verified}$ $c_{a2} = 2 \text{ in} > 1-3/4 \text{ in} \rightarrow \text{verified}$ $h = 5 \text{ in} > 4-3/4 \text{ in} \rightarrow \text{verified}$
2	17.6.1.2	Section 4.1.2 Table 3	Calculate steel capacity on a single fastener loaded in tension $\phi N_{sa} = (0.65) (18,920) = 12,298 \text{ lbf}$ Group of fasteners $\phi N_s = n \phi N_{sa} = (2) (12,298) = \mathbf{24,596 \text{ lbf}}$
3	17.6.2.1	4.1.3	Calculation concrete strength capacity on the group of fasteners loaded in tension $\phi N_{cbg} = \phi \frac{A_{NC}}{A_{Nco}} \psi_{ec,N} \psi_{ed,N} \psi_{c,N} \psi_{cp,N} N_b$
3.1	17.6.2.1	Table 3	$A_{NC} = (c_{a1} + 1.5 h_{ef}) (c_{a2} + s + 1.5 h_{ef}) = (2 + 3.32) (2.5 + 4 + 3.32) = 52.24$ $A_{Nco} = 9 (h_{ef})^2 = 9 (2.21)^2 = 43.96$
3.2	17.6.2.3.1		No load eccentricity $\rightarrow e_v = 0 \rightarrow \psi_{ec,N} = 1.00$
3.3	17.6.2.4	Table 3	$C_{a,min} < 1.5 h_{ef} \rightarrow \psi_{ed,N} = 0.7 + 0.3 \frac{c_{a,min}}{1.5 h_{ef}} = 0.7 + 0.3 \frac{2}{3.32} = 0.88$
3.4	17.6.2.5		Cracked concrete $\rightarrow \psi_{c,N} = 1.00$
3.5	17.6.2.6		Cracked concrete $\rightarrow \psi_{cp,N} = 1.00$
3.6	17.6.2.2	4.1.3	$N_b = k_c \lambda_a \sqrt{f'_c} h_{ef}^{1.5} = (21) (1.0) \sqrt{4000} (2.21)^{1.5} = 4,363 \text{ lbf}$ thus $\phi N_{cbg} = (0.65) \frac{52.24}{43.96} (1.0)(0.88)(1.0)(4,363) = \mathbf{2,965 \text{ lbf}}$
4	17.6.3.1	Section 4.1.4 Table 3	Calculate pull out strength on single fastener loaded in tension $\phi N_{p,f} = \phi \psi_{c,p} N_{p,2500} \left(\frac{f'_c}{2,500} \right)^n = (0.65)(1.00) (3,225) \left(\frac{4,000}{2,500} \right)^{0.35} = 2,470 \text{ lbf}$ Group of fasteners $\phi N_p = n \phi N_{p,f} = (2) (2,470) = \mathbf{4,940 \text{ lbf}}$
5	17.5.2	-	Governing tension strength: Minimum value of steel, concrete breakout, pull out: $\phi N_n = \min [\phi N_s; \phi N_c; \phi N_p] = \mathbf{2,965 \text{ lbf}}$
6	5.3	Section 4.2.1	Calculation of conversion factor, α , for allowable stress design $\alpha = (1.2) D + (1.6) L = (1.2) (0.30) + (1.6) (0.7) = \mathbf{1.48}$
7	-	Section 4.2.1	Calculation of allowable stress design in tension $T_{allowable,ASD} = \frac{\phi N_n}{\alpha} = \frac{2,965}{1.48} = \mathbf{2,003 \text{ lbf}}$

DIVISION: 03 00 00—CONCRETE

Section: 03 16 00—Concrete Anchors

DIVISION: 05 00 00—METALS

Section: 05 05 19—Post-Installed Concrete Anchors

REPORT HOLDER:

AEROSMITH FASTENING SYSTEMS

EVALUATION SUBJECT:

AEROSMITH SURE-BOLT® EXTREME / SURE-BOLT® / SURE-BOLT® MAX SCREW ANCHORS FOR USE IN CRACKED AND UNCRACKED CONCRETE

1.0 REPORT PURPOSE AND SCOPE

Purpose:

The purpose of this evaluation report supplement is to indicate that the Aerosmith Sure-Bolt® Extreme / Sure-Bolt® / Sure-Bolt® Max screw anchors for use in cracked and uncracked concrete, described in ICC-ES evaluation report [ESR-4414](#), have also been evaluated for compliance with the codes noted below as adopted by the Los Angeles Department of Building and Safety (LADBS).

Applicable code editions:

- 2023 City of Los Angeles Building Code ([LABC](#))
- 2023 City of Los Angeles Residential Code ([LARC](#))

2.0 CONCLUSIONS

The Aerosmith Sure-Bolt® Extreme / Sure-Bolt® / Sure-Bolt® Max screw anchors for use in cracked and uncracked concrete, described in Sections 2.0 through 7.0 of the evaluation report [ESR-4414](#), comply with the LABC Chapter 19, and the LARC, and are subject to the conditions of use described in this supplement.

3.0 CONDITIONS OF USE

The Aerosmith Sure-Bolt® Extreme / Sure-Bolt® / Sure-Bolt® Max screw anchors for use in cracked and uncracked concrete described in this evaluation report must comply with all of the following conditions:

- All applicable sections in the evaluation report [ESR-4414](#).
- The design, installation, conditions of use and identification of the anchors are in accordance with the 2021 *International Building Code*® (IBC) provisions noted in the evaluation report [ESR-4414](#).
- The design, installation and inspection are in accordance with additional requirements of LABC Chapters 16 and 17, as applicable.
- Under the LARC, an engineered design in accordance with LARC Section R301.1.3 must be submitted.
- The allowable strength and design strength values listed in the evaluation report and tables are for the connection of the anchors to the concrete. The connection between the anchors and the connected members shall be checked for capacity (which may govern).
- For use in wall anchorage assemblies to flexible diaphragm applications, anchors shall be designed per the requirements of the City of Los Angeles Information Bulletin P/BC 2023-71.

This supplement expires concurrently with the evaluation report, reissued March 2025.

DIVISION: 03 00 00—CONCRETE

Section: 03 16 00—Concrete Anchors

DIVISION: 05 00 00—METALS

Section: 05 05 19—Post-Installed Concrete Anchors

REPORT HOLDER:

AEROSMITH FASTENING SYSTEMS

EVALUATION SUBJECT:

AEROSMITH SURE-BOLT® EXTREME / SURE-BOLT® / SURE-BOLT® MAX SCREW ANCHORS FOR USE IN CRACKED AND UNCRACKED CONCRETE

1.0 REPORT PURPOSE AND SCOPE

Purpose:

The purpose of this evaluation report supplement is to indicate that the Aerosmith Sure-Bolt® Extreme / Sure-Bolt® / Sure-Bolt® Max screw anchors for use in cracked and uncracked concrete, described in ICC-ES evaluation report ESR-4414, have also been evaluated for compliance with the codes noted below.

Applicable code editions:

- 2022 California Building Code (CBC)

For evaluation of applicable chapters adopted by the [California Office of Statewide Health Planning and Development \(OSHPD\) AKA: California Department of Health Care Access and Information \(HCAI\) and the Division of the State Architect \(DSA\)](#), see Sections 2.1 and 2.2 below.

- 2022 California Residential Code (CRC)

2.0 CONCLUSIONS

The Aerosmith Sure-Bolt® Extreme / Sure-Bolt® / Sure-Bolt® / Sure-Bolt® Max screw anchors for use in cracked and uncracked concrete, described in Sections 2.0 through 7.0 of the evaluation report ESR-4414, comply with CBC Chapter 19 and CRC Section R301.1.3, provided the design and installation are in accordance with the 2021 *International Building Code*® (IBC) provisions, as applicable, noted in the evaluation report, and the additional requirements of the CBC Chapters 16 and 17, as applicable.

2.1 OSHPD:

The Aerosmith Sure-Bolt® Extreme / Sure-Bolt® / Sure-Bolt® Max screw anchors for use in cracked and uncracked concrete, described in Sections 2.0 through 7.0 of the evaluation report ESR-4414, comply with CBC amended Sections in Chapters 16, 17 and 19, and Chapters 16A, 17A and 19A, provided the design and installation are in accordance with the 2021 *International Building Code*® (IBC) provisions, as applicable, noted in the evaluation report, and the additional requirements in Sections 2.1.1 to 2.1.3 of this supplement:

2.1.1 Verification Test Requirements: The installation verification test loads, frequency, and acceptance criteria shall be in accordance with Sections 1901.3.4 [OSHPD 1R, 2 and 5] and 1910A.5 [OSHPD 1 & 4] of the CBC, as applicable.

2.1.2 Special Inspection Requirements: Periodic special inspection is required, in accordance with Section 1705.1.1 and Table 1705.3 [OSHPD 1R, 2 and 5], or Section 1705A.1.1, and Table 1705A.3 [OSHPD 1 & 4] of the CBC, as applicable. In addition, special inspection is required for special seismic certification for designated seismic system in accordance with amended Section 1705.14.3.1 [OSHPD 1R, 2 and 5] and Section 1705A.13.4 [OSHPD 1 & 4] of the CBC, as applicable.

2.1.3 Conditions of Use:

1. Where moment resistance is assumed at the base of the superstructure elements, deformation of the superstructure to foundation connection shall be considered in accordance with Section 1617A.1.15 [OSHDP 1 & 4] of the CBC.
2. The screw anchors may be loosened and retightened in accordance with Section 4.3 of the evaluation report to perform verification test requirements specified in Section 2.1.1 of this supplement. Re-use of screw anchors or screw anchor holes shall not be permitted.

2.2 DSA:

The Aerosmith Sure-Bolt® Extreme / Sure-Bolt® / Sure-Bolt® Max screw anchors for use in cracked and uncracked concrete, described in Sections 2.0 through 7.0 of the evaluation report ESR-4414, comply with CBC amended Sections in Chapters 16 and 19, and Chapters 16A, 17A and 19A, provided the design and installation are in accordance with the 2021 *International Building Code*® (IBC) provisions, as applicable, noted in the evaluation report, and the additional requirements in Sections 2.2.1 to 2.2.3 of this supplement:

2.2.1 Verification Test Requirements: The installation verification test loads, frequency, and acceptance criteria shall be in accordance with Sections 1909.2.7 [DSA-SS/CC] and 1910A.5 [DSA-SS] of the CBC, as applicable.

2.2.2 Special Inspection Requirements: Periodic special inspection is required, in accordance with Section 1705A.1.1, and Table 1705A.3 [DSA-SS, DSA-SS/CC] of the CBC. In addition, special inspection is required for special seismic certification for designated seismic system in accordance Section 1705A.13.4 [DSA-SS, DSA-SS/CC] of the CBC, as applicable.

2.2.3 Conditions of Use:

1. Where moment resistance is assumed at the base of the superstructure elements, deformation of the superstructure to foundation connection shall be considered in accordance with Section 1617.11.13 [DSA-SS/CC] or Section 1617A.1.15 [DSA-SS] of the CBC.
2. The screw anchors may be loosened and retightened in accordance with Section 4.3 of the evaluation report to perform verification test requirements specified in Section 2.1.1 of this supplement. Re-use of screw anchors or screw anchor holes shall not be permitted.

This supplement expires concurrently with the evaluation report, reissued March 2025.

DIVISION: 03 00 00—CONCRETE
Section: 03 16 00—Concrete Anchors

DIVISION: 05 00 00—METALS
Section: 05 05 19—Post-Installed Concrete Anchors

REPORT HOLDER:

AEROSMITH FASTENING SYSTEMS

EVALUATION SUBJECT:

AEROSMITH SURE-BOLT® EXTREME / SURE-BOLT® SCREW / SURE-BOLT® MAX ANCHORS FOR USE IN CRACKED AND UNCRACKED CONCRETE

1.0 REPORT PURPOSE AND SCOPE

Purpose:

The purpose of this evaluation report supplement is to indicate that the Aerosmith Sure-Bolt® Extreme / Sure-Bolt® / Sure-Bolt® Max screw anchors for use in cracked and uncracked concrete, described in ICC-ES evaluation report ESR-4414, have also been evaluated for compliance with the codes noted below.

Applicable code editions:

- 2023 Florida Building Code—Building
- 2023 Florida Building Code—Residential

2.0 CONCLUSIONS

The Aerosmith Sure-Bolt® Extreme / Sure-Bolt® / Sure-Bolt® Max screw anchors for use in cracked and uncracked concrete, described in evaluation report ESR-4414, comply with the *Florida Building Code—Building* and the *Florida Building Code—Residential*. The design requirements must be determined in accordance with the *Florida Building Code—Building* or the *Florida Building Code—Residential*, as applicable. The installation requirements noted in ICC-ES evaluation report ESR-4414 for the 2021 *International Building Code*® meet the requirements of *Florida Building Code—Building* or the *Florida Building Code—Residential*, as applicable.

Use of the Aerosmith Sure-Bolt® Extreme / Sure-Bolt® carbon steel screw anchors in dry, interior locations and Sure-Bolt® Max stainless steel anchors in interior and exterior locations has also been found to be in compliance with the High-Velocity Hurricane Zone provisions of the *Florida Building Code—Building* and *Florida Building Code—Residential* with the following condition:

- a) For anchorage to wood members, the connection subject to uplift must be designed for no less than 700 pounds (3114 N).

For products falling under Florida Rule 61G20-3, verification that the report holder's quality assurance program is audited by a quality assurance entity approved by the Florida Building Commission for the type of inspections being conducted is the responsibility of an approved validation entity (or the code official when the report holder does not possess an approval by the Commission).

This supplement expires concurrently with the evaluation report, reissued March 2025.