

# ICC-ES Evaluation Report

**ESR-3599**

Reissued November 2024

This report also contains:


- [City of LA Supplement](#)

Subject to renewal November 2026

- [CA Supplement](#)

ICC-ES Evaluation Reports are not to be construed as representing aesthetics or any other attributes not specifically addressed, nor are they to be construed as an endorsement of the subject of the report or a recommendation for its use. There is no warranty by ICC Evaluation Service, LLC, express or implied, as to any finding or other matter in this report, or as to any product covered by the report.

Copyright © 2024 ICC Evaluation Service, LLC. All rights reserved.

<p><b>DIVISION: 03 00 00— CONCRETE</b></p> <p><b>Section: 03 15 19—Cast- in Concrete Anchors</b></p> <p><b>Section: 03 16 00— Concrete Anchors</b></p>	<p><b>REPORT HOLDER:</b></p> <p><b>TOMARCO CONTRACTOR SPECIALTIES, INC. dba ISAT dba CEAS</b></p> <p><b>ADDITIONAL LISTEE:</b></p> <p><b>CEAS</b></p>	<p><b>EVALUATION SUBJECT:</b></p> <p><b>ISAT “BLUE BANGER HANGER” HEADED, CAST-IN- PLACE DECK INSERTS: PIP POURED- IN-PLACE AND SDI STEEL DECK INSERTS IN CRACKED AND UNCRACKED CONCRETE; ISAT “PUSH ROD HANGERS” (CEAS “PUSH ROD”) HEADED, CAST-IN- PLACE DECK INSERTS: ISAT-PRPIP3812 (PRPIP3812) PUSH ROD POURED-IN-PLACE AND ISAT-PRSDI3812 (PRSDI3812) PUSH ROD STEEL DECK INSERTS IN CRACKED AND UNCRACKED CONCRETE</b></p>	
--	---	---	---

## 1.0 EVALUATION SCOPE

**Compliance with the following codes:**

- 2021, 2018, 2015, 2012, 2009 and 2006 [International Building Code® \(IBC\)](#)
- 2021, 2018, 2015, 2012, 2009 and 2006 [International Residential Code® \(IRC\)](#)

**Property evaluated:**

- Structural

## 2.0 USES

The ISAT PIP and ISAT-PRPIP3812 (PRPIP3812) concrete inserts are used to resist static, wind, and seismic tension and shear loads in cracked and uncracked normal-weight concrete and sand-lightweight concrete having a specified compressive strength,  $f'_c$ , of 3,000 psi to 10,000 psi (20.7 MPa to 68.9 MPa).

The ISAT SDI and ISAT-PRSDI3812 (PRSDI3812) steel deck concrete inserts are used to resist static, wind, and seismic tension and shear loads in the soffit of cracked and uncracked normal-weight concrete and sand-lightweight concrete on metal deck having a specified compressive strength,  $f'_c$ , of 3,000 psi to 10,000 psi (20.7 MPa to 68.9 MPa).

There are four models for the PIP inserts: PIPM38, PIP143812-2, PIP381258-2, and PIP5834-2. The PIPM38 is used with a threaded rod size of  $\frac{3}{8}$  inch; the PIP143812-2 is used with a threaded rod size of  $\frac{1}{4}$  inch,

$\frac{3}{8}$  inch, or  $\frac{1}{2}$  inch; the PIP381258-2 is used with a threaded rod size of  $\frac{3}{8}$  inch,  $\frac{1}{2}$  inch, or  $\frac{5}{8}$  inch; and the PIP5834-2 is used with a threaded rod size of  $\frac{5}{8}$  inch or  $\frac{3}{4}$  inch.

There are three models for the SDI inserts: SDI143812, SDI381258, and SDI5834. The SDI143812 is used with a threaded rod size of  $\frac{1}{4}$  inch,  $\frac{3}{8}$  inch, or  $\frac{1}{2}$  inch; the SDI381258 is used with a threaded rod size of  $\frac{3}{8}$  inch,  $\frac{1}{2}$  inch, or  $\frac{5}{8}$  inch; and the SDI5834 is used with a threaded rod size of  $\frac{5}{8}$  inch or  $\frac{3}{4}$  inch.

The ISAT-PRPIP3812 insert is used with a threaded rod size of  $\frac{3}{8}$  inch and  $\frac{1}{2}$  inch. The threaded rod is installed by either directly pushing into the concrete insert or pushing into the concrete insert then tightening.

The ISAT-PRSDI3812 insert is used with a threaded rod size of  $\frac{3}{8}$  inch and  $\frac{1}{2}$  inch. The threaded rod is installed by either directly pushing into the concrete insert or pushing into the concrete insert then tightening.

For any application that includes shear loads, the largest size of threaded rod specified for each insert must be used.

Reference to “inserts” in this report refers to the manufactured specialty anchorage products (PIPs, SDIs, ISAT-PRPIP3812, and ISAT-PRSDI3812) used in concrete; reference to “anchors” in this report refers to the installed inserts in concrete with threaded rods.

The inserts are alternatives to cast-in anchors described in Section 1901.3 of the 2021, 2018 and 2015 IBC, Sections 1908 and 1909 of the 2012 IBC and Sections 1911 and 1912 of the 2009 and 2006 IBC. The anchors may be used where an engineered design is submitted in accordance with Section R301.1.3 of the IRC. See [Table 1](#) for a correlation of product names between the report holder and the additional listee.

## 3.0 DESCRIPTION

### 3.1 PIP, SDI, ISAT-PRPIP3812, and ISAT-PRSDI3812 Inserts:

The PIP inserts are cast-in concrete inserts. The insert consists of a steel internally threaded headed insert (anchor body), an outer plastic sleeve, and nails used to attach the insert to the inside surface of concrete formwork. The PIP inserts are illustrated in [Figures 1](#) and [1C](#). The internally threaded insert is manufactured from carbon steel GB/T 6478 Grade U40088 (ML08A1), GB/T 700 Grade Q195, or JIS G3507-1 Grade SWRCH8A. The PIP inserts have a minimum 5.1  $\mu\text{m}$  (0.0002-inch) zinc plating. The plastic sleeve is available with a standard base and a wide base, and is fabricated from high-impact Type J340 PP (polypropylene) or equivalent. The plastic sleeve thickness is a maximum of 0.053 inch (1.35 mm).

The ISAT-PRPIP3812 inserts are cast-in concrete inserts. The insert consists of a steel internally threaded headed insert (anchor body), an outer plastic sleeve, and nails used to attach the insert to the inside surface of concrete formwork. The ISAT-PRPIP3812 insert is illustrated in [Figure 1A](#) ([Figure 1B](#) illustrates the PRPIP3812 insert). The internally threaded insert is manufactured from carbon steel GB/T 6478 Grade ML08A1, ASTM A29 Grade 1010, or JIS G3507-1 Grade SWRCH8A. The ISAT-PRPIP3812 inserts have a minimum 5.1  $\mu\text{m}$  (0.0002-inch) zinc plating. The plastic sleeve is available with a standard base and a wide base and is fabricated from high-impact Type J340 PP (polypropylene) or equivalent.

The SDI inserts are cast-in concrete inserts. The insert consists of a steel internally threaded headed insert (anchor body), an outer spring, a plastic sleeve, and a washer (base plate). The SDI insert is illustrated in [Figure 2](#). The internally threaded insert and washer are manufactured from carbon steel GB/T 6478 Grade U40088 (ML08A1), GB/T 700 Grade Q195, or JIS G3507-1 Grade SWRCH8A. The SDI inserts have a minimum 5.1  $\mu\text{m}$  (0.0002-inch) zinc plating. The spring is manufactured from #72A or JISG3521-91 spring steel. The plastic sleeve is fabricated from high-impact Type J340 PP (polypropylene) or equivalent.

The ISAT-PRSDI3812 inserts are cast-in concrete inserts. The insert consists of a steel internally threaded headed insert (anchor body), an outer spring, a plastic sleeve, and a washer (base plate). The ISAT-PRSDI3812 insert is illustrated in [Figure 2A](#) ([Figure 2B](#) illustrates the PRSDI3812 insert). The internally threaded insert is manufactured from carbon steel GB/T 6478 Grade ML08A1, ASTM A29 Grade 1010, or JIS G3507-1 Grade SWRCH8A. The ISAT-PRSDI3812 inserts have a minimum 5.1  $\mu\text{m}$  (0.0002-inch) zinc plating. The spring is manufactured from ASTM A29 Grade 1070, JIS G3506 Grade SWRH72A, or GB/T 1222 Grade 70 spring steel. The plastic sleeve is fabricated from high-impact Type J340 PP (polypropylene) or equivalent.

The anchor assembly is comprised of a PIP, SDI, ISAT-PRPIP3812 or ISAT-PRSDI3812 insert with a threaded rod. For ISAT-PRPIP3812 and ISAT-PRSDI3812 inserts, the anchor assembly may include an ASTM A307 Grade A (or materially equivalent) threaded rod with an optional factory crimped engagement

marker at one end to indicate proper installation. The PIP and ISAT-PRPIP3812 inserts are installed on the inside surface of wood formwork and the nails driven into the form until the insert base sits flush on the form. The SDI and ISAT-PRSDI3812 inserts are installed in a predrilled hole in the topside of the metal deck, and impacted with sufficient force to compress the spring and drive the flared plastic fins completely through the hole. Concrete can then be cast over the insert.

### 3.2 Concrete:

Normal-weight and sand-lightweight concrete must conform to Sections 1903 and 1905 of the IBC.

### 3.3 Steel Deck Panels:

Steel deck panels must be in accordance with the configuration in [Figure 4](#) or [Figure 4A](#) and have a minimum base steel thickness of 20 gage [0.035 inch (0.899 mm)]. Steel must comply with ASTM A653/A653M SS Grade 50 and have a minimum yield strength of 50,000 psi (345 MPa).

## 4.0 DESIGN AND INSTALLATION

### 4.1 Strength Design:

For any application that includes shear loads, the largest size of threaded rod specified for each insert must be used, that is:  $\frac{1}{2}$ -inch threaded rod only for PIP143812-2, SDI143812, ISAT-PRPIP3812, and ISAT-PRSDI3812;  $\frac{5}{8}$ -inch threaded rod only for PIP381258-2 and SDI381258; and  $\frac{3}{4}$ -inch threaded rod only for PIP5834-2 and SDI5834. Smaller diameter threaded rods are permitted to resist tension loads only.

**4.1.1 General:** Design strength of anchors complying with the 2021 IBC, as well as Section R301.1.3 of the 2021 IRC must be determined in accordance with ACI 318-19 Chapter 17 and this report.

Design strength of anchors complying with the 2018 and 2015 IBC as well as Section R301.1.3 of the 2018 and 2015 IRC must be determined in accordance with ACI 318-14 Chapter 17 and this report.

Design strength of anchors complying with the 2012 IBC as well as Section R301.1.3 of the 2012 IRC, must be determined in accordance with ACI 318-11 Appendix D and this report.

Design strength of anchors complying with the 2009 IBC and Section R301.1.3 of the 2009 IRC must be determined in accordance with ACI 318-08 Appendix D and this report.

Design strength of anchors complying with the 2006 IBC and Section R301.1.3 of the 2006 IRC must be in accordance with ACI 318-05 Appendix D and this report.

Design parameters provided in [Tables 2](#), [2A](#), [3](#), and [3A](#) of this report are based on the 2021 IBC (ACI 318-19), 2018 and 2015 IBC (ACI 318-14) and the 2012 IBC (ACI 318-11), as applicable, unless noted otherwise in Sections 4.1.1 through 4.1.12. The strength design of anchors must comply with ACI 318-19 17.5.1.2, ACI 318-14 17.3.1 or ACI 318-11 D.4.1, as applicable, except as required in ACI 318-19 17.10, ACI 318-14 17.2.3 or ACI 318-11 D.3.3, as applicable.

Strength reduction factors,  $\phi$ , as given in ACI 318-19 17.5.3, ACI 318-14 17.3.3 and ACI 318-11 D.4.3, as applicable, for cast-in headed anchors, must be used for load combinations calculated in accordance with Section 1605.1 of the 2021 IBC or Section 1605.2 of the 2018, 2015, and 2012 IBC, Section 5.3 of ACI 318-14 and Section 9.2 of ACI 318-11. Strength reduction factors,  $\phi$ , as given in ACI 318-11 D.4.4 must be used for load combinations calculated in accordance with ACI 318-11 Appendix C. An example calculation in accordance with the 2012, 2015 and 2018 IBC is provided in [Figure 9](#). The value of  $f'_c$  used in the calculations must be limited to a maximum of 10,000 psi (68.9 MPa), in accordance with ACI 318-19 17.3.1, ACI 318-14 17.2.7 or ACI 318-11 D.3.7, as applicable.

The pullout strength in tension is not decisive for design and does not need to be evaluated.

**4.1.2 Requirements for Static Steel Strength in Tension:** The nominal static steel strength in tension,  $N_{sa}$ , of a single anchor must be calculated in accordance with ACI 318-19 17.6.1.2, ACI 318-14 17.4.1 or ACI 318-11 D.5.1, as applicable, for the threaded rod, not to exceed the values of  $N_{sa,insert}$  in [Tables 2](#), [2A](#), [3](#) and [3A](#) of this report. Strength reduction factors,  $\phi$ , corresponding to non-ductile steel shall be used when  $\phi N_{sa,insert}$  controls the design strength for PIP and SDI inserts, except for the PIPM38 insert. Strength reduction factors,  $\phi$ , corresponding to ductile steel shall be used when  $\phi N_{sa,insert}$  controls the design strength for PIPM38, ISAT-PRPIP3812 and ISAT-PRSDI3812 inserts. When the threaded rod strength controls, the strength reduction factor,  $\phi$ , corresponding to the threaded rod shall be used.

**4.1.3 Requirements for Static Concrete Breakout Strength in Tension:** For the PIP, SDI, ISAT-PRPIP3812, and ISAT-PRSDI3812 anchors, the nominal concrete breakout strength of a single anchor or group of anchors in tension,  $N_{cb}$  or  $N_{cbg}$ , respectively, must be calculated in accordance with ACI 318-19 17.6.2,

ACI 318-14 17.4.2 or ACI 318-11 D.5.2 as applicable for cast-in bolts, with modifications as described in this section, and with [Figures 1, 1A, 1C](#) ([Figure 1B](#) for PRPIP3812), [2](#), and [2A](#) ([Figure 2B](#) for PRSDI3812) of this report. The basic concrete breakout strength in tension,  $N_b$ , must be calculated in accordance with ACI 318-19 17.6.2.2, ACI 318-14 17.4.2.2 or ACI 318-11 D.5.2.2, as applicable, using the values of  $h_{ef}$  given in [Tables 2, 2A, 3](#), and [3A](#), and  $k_c = 24$ . The nominal concrete breakout strength in tension in regions where analysis indicates no cracking in accordance with ACI 318-19 17.6.2.5.1, ACI 318-14 17.4.2.6 or ACI 318-11 D.5.2.6, as applicable, must be calculated with  $\psi_{c,N} = 1.25$ . For the SDI and ISAT-PRSDI3812 inserts installed in the soffit of sand-lightweight or normal-weight concrete on steel deck, the contribution of the metal deck strength must be ignored and the calculations of  $A_{Nc} / A_{Nco}$  and  $c_{a,min}$  (minimum edge distance) must be based on [Figure 5](#).

**4.1.4 Requirements for Static Side-Face Blowout Strength in Tension:** For the PIP and ISAT-PRPIP3812 anchors, the nominal side-face blowout strength of a headed insert,  $N_{sb}$ , must be calculated in accordance with ACI 318-19 17.6.4.1, ACI 318-14 17.4.4.1 or ACI 318-11 D.5.4.1, as applicable, for the cast-in headed insert, in cracked and uncracked concrete, as applicable.

For the SDI and ISAT-PRSDI3812 inserts installed in the soffit of sand-lightweight or normal-weight concrete on steel deck floor and roof assemblies as shown in [Figures 4](#) and [4A](#), respectively, calculation of the concrete side blowout strength is not required.

**4.1.5 Requirements for Static Steel Strength in Shear:** For any applications having a shear component, the largest size of threaded rod specified for each insert must be used.

For PIP and ISAT-PRPIP3812 anchors, the nominal steel strength in shear,  $V_{sa}$ , of a single PIP insert and ISAT-PRPIP3812 insert are given in [Tables 2](#) and [2A](#), respectively, and must be used in lieu of the values derived by calculation from ACI 318-19 Eq. 17.7.1.2a or 17.7.1.2b, ACI 318-14 Eq. 17.5.1.2a or 17.5.1.2b; or ACI 318-11 Eq. D-28 or D-29, as applicable.

For SDI and ISAT-PRSDI3812 anchors, the nominal steel strength in shear,  $V_{sa,deck,lower}$  and  $V_{sa,deck,upper}$ , of a single SDI insert and ISAT-PRSDI3812 insert, at lower flute and upper flute, respectively, are given in [Tables 3](#) and [3A](#) of this report, respectively, and must be used in lieu of the values derived by calculation from ACI 318-19 Eq. 17.7.1.2a or 17.5.1.2b, ACI 318-14 Eq. 17.5.1.2a or 17.5.1.2b; or ACI 318-11 Eq. D-28 or D-29, as applicable.

**4.1.6 Requirements for Static Concrete Breakout Strength in Shear:** For PIP and ISAT-PRPIP3812 anchors, the nominal concrete breakout strength of a single anchor or group of anchors in shear,  $V_{cb}$  or  $V_{cbg}$ , respectively, must be calculated in accordance with ACI 318-19 17.7.2, ACI 318-14 17.5.2 or ACI 318-11 D.6.2, as applicable. The basic concrete breakout strength,  $V_b$ , must be calculated in accordance with ACI 318-19 17.7.2.2, ACI 318-14 17.5.2.2 or ACI 318-11 D.6.2.2, as applicable, based on the values provided in [Tables 2](#) and [2A](#). The value of  $l_e$  used in ACI 318-19 Eq. 17.7.2.2.1a, ACI 318-14 Eq. 17.5.2.2a or ACI 318-11 Eq. D-33, as applicable, must be taken as no greater than the lesser of  $h_{ef}$  or  $8d_a$ .

For the SDI and ISAT-PRSDI3812 inserts installed in the soffit of sand-lightweight or normal-weight concrete on steel deck floor and roof assemblies, as shown in [Figure 4](#) and [4A](#), respectively, calculation of the concrete breakout strength in shear is not required.

**4.1.7 Requirements for Static Concrete Pryout Strength in Shear:** For PIP and ISAT-PRPIP3812 anchors, the nominal concrete pryout strength of a single anchor or group of anchors,  $V_{cp}$  or  $V_{cpg}$ , respectively, must be calculated in accordance with ACI 318-19 17.7.3, ACI 318-14 17.5.3 or ACI 318-11 D.6.3, as applicable.

For the SDI and ISAT-PRSDI3812 inserts installed in the soffit of sand-lightweight or normal-weight concrete over profile steel deck floor and roof assemblies, as shown in [Figure 4](#) and [4A](#), respectively, calculation of the concrete pry-out strength in accordance with ACI 318-19 17.7.3, ACI 318-14 17.5.3 or ACI 318-11 D.6.3, as applicable, is not required.

#### **4.1.8 Requirements for Seismic Design:**

**4.1.8.1 General:** For load combinations including seismic, the design must be performed in accordance with ACI 318-19 17.10, ACI 318-14 17.2.3 or ACI 318-11 D.3.3, as applicable. Modifications to ACI 318-19 17.10 or ACI 318-14 17.2.3 shall be applied under Section 1905.1.8 of the 2021, 2018 and 2015 IBC. For the 2012 IBC, Section 1905.1.9 shall be omitted. Modifications to ACI 318 (-08 and -05) D.3.3 shall be applied under Section 1908.1.9 of the 2009 IBC, or Section 1908.1.16 of the 2006 IBC, as applicable.

The nominal concrete breakout strength (for PIP, SDI, ISAT-PRPIP3812, and ISAT-PRSDI3812 anchors) and nominal concrete side-face blowout strength (for PIP and ISAT-PRPIP3812 anchors only) for anchors in

tension, and the nominal concrete breakout strength and pryout strength (for PIP, ISAT-PRPIP3812, and upper flute of SDI and ISAT-PRSDI3812 anchors) for anchors in shear, must be calculated in accordance with ACI 318-19 17.6 and 17.7, ACI 318-14 17.4 and 17.5 or ACI 318-11 D.5 and D.6, as applicable. The anchors may be installed in Seismic Design Categories A through F of the IBC.

The anchors comply with ACI 318 (-19 or -14) 2.3 or ACI 318-11 D.1, as applicable, as brittle steel elements and must be designed in accordance with ACI 318-19 17.10.5, 17.10.6, 17.10.7; ACI 318-14 17.2.3.4, 17.2.3.5, 17.2.3.6, or 17.2.3.7; ACI 318-11 D.3.3.4, D.3.3.5, D.3.3.6 or D.3.3.7; ACI 318-08 D.3.3.4, D.3.3.5 or D.3.3.6; or ACI 318-05 D.3.3.4 or D.3.3.5, as applicable.

**4.1.8.2 Seismic Tension:** For PIP and ISAT-PRPIP3812 anchors, the nominal steel strength in tension,  $N_{sa}$ , of a single anchor must be calculated in accordance with ACI 318-19 17.6.1, ACI 318-14 17.4.1 or ACI 318-11 D.5.1, as applicable, for the threaded rod, not to exceed the insert nominal steel strength,  $N_{sa,insert,eq}$ , provided in [Tables 2](#) and [2A](#), respectively; the nominal concrete breakout strength for anchors in tension must be calculated in accordance with ACI 318-19 17.6.2, ACI 318-14 17.4.2 or ACI 318-11 D.5.2, as applicable, as described in Section 4.1.3 of this report; the nominal concrete side-face blowout strength must be calculated in accordance with ACI 318-19 17.6.4.1 and 17.6.4.2, ACI 318-14 17.4.4.1 and 17.4.4.2, or ACI 318-11 D.5.4.1 and D.5.4.2, as applicable, and Section 4.1.4 of this report.

For SDI and ISAT-PRSDI3812 anchors, the nominal steel strength in tension,  $N_{sa}$ , of a single anchor must be calculated in accordance with ACI 318-19 17.6.1, ACI 318-14 17.4.1 or ACI 318-11 D.5.1, as applicable, for the threaded rod, not to exceed the insert nominal steel strength,  $N_{sa,insert,eq}$ , provided in [Table 3](#) and [Table 3A](#), respectively. Calculation of the nominal concrete breakout strength in tension and the nominal concrete pullout strength is not required.

**4.1.8.3 Seismic Shear:** For PIP and ISAT-PRPIP3812 anchors, the nominal concrete breakout strength and pryout strength in shear must be calculated in accordance with ACI 318-19 17.7.2 and 17.7.3, ACI 318-14 17.5.2 and 17.5.3, or ACI 318-11 D.6.2 and D.6.3, as applicable, as described in Sections 4.1.6 and 4.1.7 of this report. In accordance with ACI 318-19 17.7.1.2, ACI 318-14 17.5.1.2 or ACI 318-11 D.6.1.2, as applicable, the appropriate value for nominal steel strength for seismic loads,  $V_{sa,eq}$ , described in [Table 2](#) and [Table 2A](#), respectively, must be used in lieu of  $V_{sa}$ , as applicable.

For SDI and ISAT-PRSDI3812 anchors, the nominal concrete breakout strength and pryout strength in shear, calculations in accordance with ACI 318-19 17.7.2 and 17.7.3, ACI 318-14 17.5.2 and 17.5.3 or ACI 318-11 D.6.2 and D.6.3, as applicable, as described in Sections 4.1.6 and 4.1.7 of this report, are not required. In accordance with ACI 318-19 17.7.1.2, ACI 318-14 17.5.1.2 or ACI 318-11 D.6.1.2, as applicable, the appropriate value for nominal steel strength for seismic loads,  $V_{sa,deck,lower,eq}$  or  $V_{sa,deck,upper,eq}$ , described in [Table 3](#) and [Table 3A](#), respectively, for lower flute or upper flute, respectively, must be used in lieu of  $V_{sa}$  as applicable.

**4.1.9 Requirements for Interaction of Tensile and Shear Forces:** For anchors or groups of anchors that are subject to the effects of combined tension and shear forces, the influence of bending on tension values when loaded in shear must be considered. The design engineer must verify the validity of the interaction equation in ACI 318-19 17.8, ACI 318-14 17.6 or ACI 318-11 D.7, as applicable.

**4.1.10 Requirements for Minimum Member Thickness, Minimum Anchor Spacing and Minimum Edge Distance:** Requirements on headed cast-in specialty anchor edge distance, spacing, member thickness, and concrete strength must be in accordance with the requirements in ACI 318 as applicable for cast-in bolts.

For SDI and ISAT-PRPSDI3812 inserts installed in the soffit of sand-lightweight or normal-weight concrete over profile steel deck floor and roof assemblies, the anchors must be installed in accordance with [Figure 4](#) and [Figure 4A](#), respectively, and shall have a minimum axial spacing along the flute equal to  $3h_{ef}$ .

**4.1.11 Requirements for Critical Edge Distance:** The critical edge distance,  $c_{ac}$ , must be calculated in accordance with ACI 318-19 17.9.2, ACI 318-14 17.7.2 or ACI 318-11 D.8.2, as applicable. The modification factor  $\psi_{cp,N} = 1.0$  in accordance with ACI 318-14 17.4.2.5 or ACI 318-11 D.5.2.5, as applicable.

**4.1.12 Sand-lightweight Concrete:** For ACI 318 (-19, -14, -11 and -08), when the PIP and ISAT-PRPIP3812 anchors are used in sand-lightweight concrete, the modification factor  $\lambda_a$  or  $\lambda$ , respectively, for concrete breakout strength must be taken as 0.85 according to ACI 318-19 17.2.4 (2021 IBC), ACI 318-14 17.2.6 (2018 and 2015 IBC), ACI 318-11 D.3.6 (2012 IBC) or ACI 318-08 D.3.4 (2009 IBC). For ACI 318-05, the values of  $N_b$  and  $V_b$  determined in accordance with this report must be modified in accordance with the provisions of ACI 318-05 D.3.4.

For SDI and ISAT-PRSDI3812 inserts installed in the soffit of sand-lightweight concrete-filled steel deck and floor and roof assemblies, this reduction is not required. Values are presented in [Table 3](#) and [Table 3A](#), respectively, and installation details are shown in [Figure 4](#) and [Figure 4A](#), respectively.

## 4.2 Allowable Stress Design (ASD):

**4.2.1 General:** Design values for use with allowable stress design (working stress design) load combinations calculated in accordance with Section 1605.1 of the 2021 IBC, Section 1605.3 of the 2018, 2015 and 2012 IBC, must be established as follows:

$$T_{allowable,ASD} = \frac{\phi N_n}{\alpha}$$

$$V_{allowable,ASD} = \frac{\phi V_n}{\alpha}$$

where:

$T_{allowable,ASD}$  = Allowable tension load (lbf or kN).

$V_{allowable,ASD}$  = Allowable shear load (lbf or kN).

$\phi N_n$  = Lowest design strength of an anchor or anchor group in tension as determined in accordance with ACI 318 (-19 and -14) Chapter 17 and 2018 and 2015 IBC Section 1905.1.8, ACI 318-11 and -08 Appendix D and 2009 IBC Section 1908.1.9, ACI 318-05 Appendix D and 2006 IBC Section 1908.1.16, and Section 4.1 of this report, as applicable (lbf or N). For the 2012 IBC, Section 1905.1.9 shall be omitted.

$\phi V_n$  = Lowest design strength of an anchor or anchor group in shear as determined in accordance with ACI 318 (-19 and -14) Chapter 17 and 2018 and 2015 IBC Section 1905.1.8, ACI 318-11 and -08 Appendix D and 2009 IBC Section 1908.1.9, ACI 318-05 Appendix D and 2006 IBC Section 1908.1.16, and Section 4.1 of this report, as applicable (lbf or N). For the 2012 IBC, Section 1905.1.9 shall be omitted.

$\alpha$  = Conversion factor calculated as a weighted average of the load factors for the controlling load combination. In addition,  $\alpha$  must include all applicable factors to account for non-ductile failure modes and required over-strength.

The requirements for member thickness, edge distance and spacing, described in this report, must apply. Examples of allowable stress design values for tension and shear for illustrative purposes are shown in [Tables 4, 5, 6, and 7](#).

**4.2.2 Interaction of Tensile and Shear Forces:** For anchors or groups of anchors that are subject to the effects of combined tension and shear forces, the influence of bending on tension values when loaded in shear must be considered. The design engineer must verify the validity of the interaction equation in ACI 318-19 17.8, ACI 318-14 17.6 or ACI 318-11, -08, -05 D.7, as applicable, as follows:

For shear loads  $V_{applied} \leq 0.2V_{allowable,ASD}$ , the full allowable load in tension must be permitted.

For tension loads  $T_{applied} \leq 0.2T_{allowable,ASD}$ , the full allowable load in shear must be permitted.

For all other cases:

$$\frac{T_{applied}}{T_{allowable,ASD}} + \frac{V_{applied}}{V_{allowable,ASD}} \leq 1.2 \quad (\text{Eq-1})$$

## 4.3 Installation:

For the PIP inserts, installation parameters are provided in [Table 2](#) and in [Figure 3](#) and [Figure 6](#). PIP inserts must be positioned on wood formwork with all three nails in contact with the form. The head of the PIP must be impacted with sufficient force to drive nails all the way into the wood until the plastic base sits flush and tight against the form. From beneath the deck, following the concrete pour and wood form removal, exposed nails must be broken away and an all-thread rod must be screwed into the internal threads of the PIP. The rod must be tightened until fully seated in the insert which will result in a minimum thread engagement equal to one rod diameter.

For the ISAT-PRPIP3812 insert, installation parameters are provided in [Table 2A](#) and in [Figure 3](#), [Figure 6A](#) and [Figure 8](#). PRPIP inserts must be positioned on wood formwork with all three nails in contact with the form. The head of the ISAT-PRPIP3812 must be impacted with sufficient force to drive nails all the way into the wood until the plastic base sits flush and tight against the form. From beneath the deck, following the concrete pour and wood form removal, exposed nails must be broken away and install the all-threaded rod into the internal threads of the ISAT-PRPIP3812. Push the threaded rod into the ISAT-PRPIP3812 insert until the end of the threaded rod contacts the bottom of the steel barrel. Refer to [Figure 8](#) for the required threaded rod engagement into the ISAT-PRPIP3812 insert for proper installation. When applicable, the optional engagement marker on the threaded rod will seat flush with the bottom of the insert indicating proper threaded rod engagement. For seismic restraint anchorage, use a ½-inch diameter threaded rod, insert threaded rod into the ISAT-PRPIP3812 until the end of the threaded rod contacts the bottom of the steel barrel. Optionally, after the threaded rod is inserted in the concrete insert, it can be further tightened. Mount seismic bracket on exposed rod and flush with the underside of the deck, then install a hex nut hand tight plus ½ turn (minimum).

For the SDI inserts, installation parameters are provided in [Table 2](#) and in [Figure 4](#) and [Figure 7](#). A hole must be made in the metal deck using a step-drill, hole saw, or deck punch in accordance with the following hole diameters: SDI143812 (7/8-inch diameter), SDI381258 (1<sup>3</sup>/<sub>16</sub>-inch diameter), and SDI5834 (1<sup>1</sup>/<sub>4</sub>-inch diameter). The SDI must be placed in the hole, then the head of the insert must be impacted with sufficient force to compress the outer spring and drive the flared plastic fins completely through the hole in the metal deck. The SDI metal base plate may be screwed to the deck for additional stability (optional). Before or after SDI insertion in deck, a threaded rod must be inserted through the plastic thread protector nozzle until contact is made with the inner steel barrel. The threaded rod must then be screwed into the SDI internal threads. The rod must be tightened until fully seated in the insert, which will result in a thread engagement equal to a minimum of one rod diameter. SDI inserts are permitted to be installed in either the upper or lower flute of the metal deck. For installation in the lower flute, the maximum offset from the flute centerline to the SDI centerline must be no greater than 1<sup>1</sup>/<sub>4</sub> inches. The SDI inserts are suitable for installation anywhere across the upper flute.

For the ISAT-PRSDI3812 insert, installation parameters are provided in [Table 3A](#) and in [Figure 4A](#), [Figure 7A](#) and [Figure 8](#). A 1<sup>1</sup>/<sub>4</sub>-inch diameter hole must be made in the metal deck using a step-drill, hole saw, or deck punch. The ISAT-PRSDI3812 must be placed in the hole, then the head of the insert must be impacted with sufficient force to compress the outer spring and drive the flared plastic fins completely through the hole in the metal deck. The ISAT-PRSDI3812 metal base plate may be screwed to the deck for additional stability (optional). Before or after ISAT-PRSDI3812 insertion in deck, insert threaded rod through finned plastic nozzle until the end of the threaded rod contacts the bottom of the steel barrel. Refer to [Figure 8](#) for the required threaded rod engagement into the ISAT-PRSDI3812 insert for proper installation. When applicable, the optional engagement marker on the threaded rod will seat flush with the bottom of the insert indicating proper threaded rod engagement. For seismic restraint anchorage, from beneath deck, trim away plastic nozzle flush with projecting ¾-inch long metal barrel of ISAT-PRSDI3812. Use a ½-inch diameter threaded rod, insert threaded rod into the ISAT-PRSDI3812 until the end of the threaded rod contacts the bottom of the steel barrel, then fully tighten the threaded rod. Mount seismic bracket on exposed rod and flush with the underside of the deck, then install a hex nut hand tight plus ½ turn (minimum).

Installation of PIP, SDI, ISAT-PRPIP3812, and ISAT-PRSDI3812 inserts must be in accordance with this evaluation report and the manufacturer's published installation instruction (MPII) depicted in [Figures 6, 6A, 7, and 7A](#). In the event of a conflict between this report and the MPII, this report governs.

#### 4.4 Special Inspection:

Periodic special inspection is required in accordance with Section 1705.1.1 and Table 1705.3 of the 2021, 2018, 2015 or 2012 IBC, or Section 1704.15 and Table 1704.4 of the 2009 IBC, or Section 1704.13 of the 2006 IBC, as applicable. For each type of headed cast-in specialty insert system, the manufacturer must submit inspection procedures to verify proper usage.

The special inspector must make periodic inspections during installation of the headed cast-in specialty inserts to verify insert type, insert dimensions, concrete type, concrete compressive strength, insert spacing, edge distances, concrete member thickness, insert embedment, threaded rod fully seated into insert, and adherence to the manufacturer's printed installation instructions. The special inspector must be present as often as required in accordance with the "statement of special inspection." Under the IBC, additional requirements as set forth in Sections 1705, 1706 and 1707 must be observed, where applicable.

## 5.0 CONDITIONS OF USE:

The PIP, SDI, ISAT-PRPIP3812, and ISAT-PRSDI3812 concrete specialty anchors described in this report are acceptable alternatives to what is specified in the codes listed in Section 1.0 of this report, subject to the following conditions:

- 5.1 Specialty inserts are limited to dry interior locations.
- 5.2 Specialty insert sizes, dimensions, minimum embedment depths, and other installation parameters are as set forth in this report.
- 5.3 Specialty inserts must be installed in accordance with the manufacturer's published instructions and this report. In case of conflict, this report governs.
- 5.4 Specialty inserts must be limited to use in cracked and uncracked normal-weight concrete and sand-lightweight concrete having a specified compressive strength,  $f'_c$ , of 3,000 psi to 10,000 psi (20.7 MPa to 68.9 MPa) for the PIP and ISAT-PRPIP3812 inserts, and in cracked and uncracked normal-weight or sand-lightweight concrete over metal deck having a minimum specified compressive strength,  $f'_c$ , of 3,000 psi (20.7 MPa) for the SDI and ISAT-PRSDI3812 inserts.
- 5.5 The values of  $f'_c$  used for calculation purposes must not exceed 10,000 psi (68.9 MPa).
- 5.6 The concrete shall have achieved its minimum design strength prior to loading of the specialty inserts.
- 5.7 Strength design values must be established in accordance with Section 4.1 of this report.
- 5.8 Allowable design values are established in accordance with Section 4.2.
- 5.9 Specialty insert spacing and edge distance as well as minimum member thickness must comply with ACI 318-19 17.9, (2021 IBC), ACI 318-14 Section 17.7 (2018 and 2015 IBC) or ACI 318 Section D.8 (2012 and 2009 IBC), as applicable, for cast-in-place headed anchors.
- 5.10 Prior to installation, calculations and details demonstrating compliance with this report must be submitted to the code official. The calculations and details must be prepared by a registered design professional where required by the statutes of the jurisdiction in which the project is to be constructed.
- 5.11 Performance and serviceability of deflection sensitive attachments and equipment shall be addressed, when threaded rod axial deflection exists, by installing a hex nut and washer at the interface of the concrete insert and threaded rod.
- 5.12 Since an ICC-ES acceptance criteria for evaluating data to determine the performance of the specialty inserts subjected to fatigue or shock loading is unavailable at this time, the use of these inserts under such conditions is beyond the scope of this report.
- 5.13 Specialty inserts may be installed in regions of concrete where analysis indicates cracking may occur ( $f_t > f_{cr}$ ), subject to the conditions of this report.
- 5.14 Specialty inserts may be used to resist short-term loading due to wind or seismic forces in locations designated as Seismic Design Categories A through F of the IBC, subject to the conditions of this report.
- 5.15 Where not otherwise prohibited in the code, PIP, SDI, ISAT-PRPIP3812, and ISAT-PRSDI3812 inserts are permitted for use with fire-resistance-rated construction provided that at least one of the following conditions is fulfilled:
  - Headed cast-in specialty inserts that support a fire-resistance-rated envelope or a fire-resistance-rated membrane are protected by approved fire-resistance-rated materials, or have been evaluated for resistance to fire exposure in accordance with recognized standards.
  - Headed cast-in specialty inserts are used to resist wind or seismic forces only.
  - Headed cast-in specialty inserts are used to support nonstructural elements.
- 5.16 Use of zinc-coated carbon steel anchors is limited to dry, interior locations.
- 5.17 Special inspection must be provided in accordance with Section 4.4.
- 5.18 Specialty inserts are manufactured under an approved quality control program with inspections by ICC-ES.



## 6.0 EVIDENCE SUBMITTED

- 6.1 Data in accordance with the [ICC-ES Acceptance Criteria for Headed Cast-in Specialty Inserts in Concrete \(AC446\)](#), dated August 2018 (editorially revised May 2021).
- 6.2 Quality control documentation.

## 7.0 IDENTIFICATION

7.1 The inserts are identified by packaging labeled with the manufacturer’s name (ISAT) and contact information, insert name, insert size, and evaluation report number (ESR-3599). The inserts have the letters ISAT PIP, ISAT SDI, ISAT-PRPIP3812, or ISAT-PRSDI3812 and the specific part number size embossed atop the head of the insert, and these are visible for verification.

7.2 The report holder’s contact information is the following:

**TOMARCO CONTRACTOR SPECIALTIES, INC.**  
**dba ISAT dba CEAS**  
**14848 NORTHAM STREET**  
**LA MIRADA, CALIFORNIA 90638**  
**(714) 994-6353**  
[www.isatsb.com](http://www.isatsb.com)  
[arubalcava@isatsb.com](mailto:arubalcava@isatsb.com)

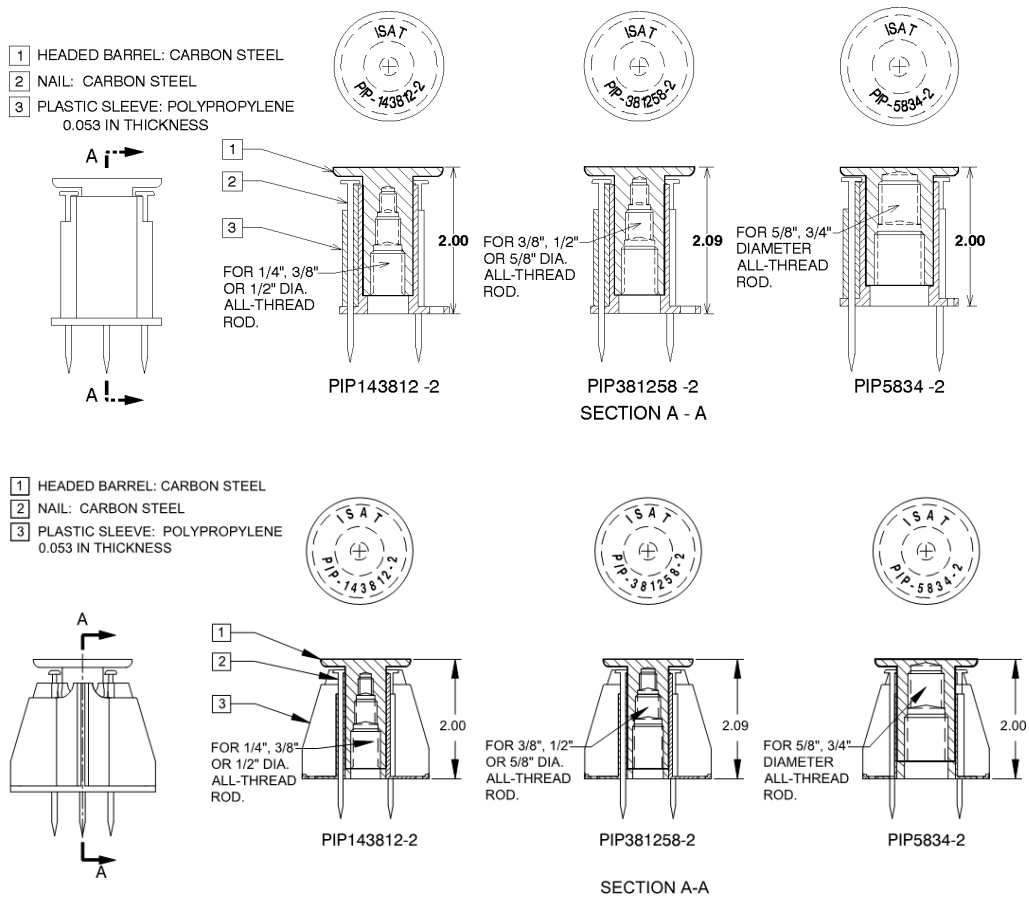
7.3 The Additional Listee’s contact information is the following:

**CEAS**  
**14848 NORTHAM STREET**  
**LA MIRADA, CALIFORNIA 90638**  
**(877) 466-2327**

**TABLE 1—CORRELATION OF PRODUCT NAMES**

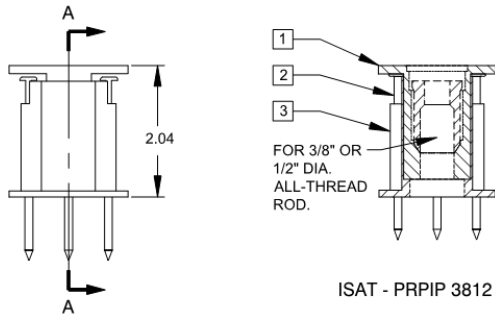
ISAT	CEAS
PIP	N/A <sup>1</sup>
SDI	N/A <sup>1</sup>
ISAT-PRPIP3812	PRPIP3812
ISAT-PRSDI3812	PRSDI3812

<sup>1</sup>N/A = Not Applicable.

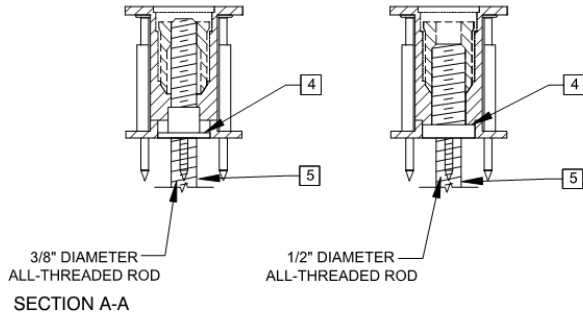


**FIGURE 1—PIP CAST-IN-PLACE INSERTS FOR FORM POUR CONCRETE  
 (TOP—STANDARD BASE; BOTTOM—WIDE BASE)**

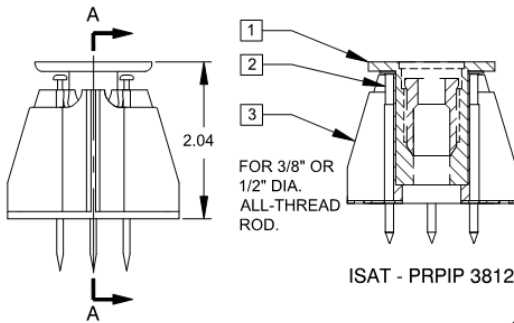
- 1 HEADED BARREL: CARBON STEEL
- 2 NAIL: CARBON STEEL
- 3 PLASTIC SLEEVE: POLYPROPYLENE
- 4 ENGAGEMENT MARKING (OPTIONAL)
- 5 ALL THREADED ROD W/ INTEGRAL ENGAGEMENT MARKING (OPTIONAL)



ISAT - PRPIP 3812



- 1 HEADED BARREL: CARBON STEEL
- 2 NAIL: CARBON STEEL
- 3 PLASTIC SLEEVE: POLYPROPYLENE
- 4 ENGAGEMENT MARKING (OPTIONAL)
- 5 ALL THREADED ROD W/ INTEGRAL ENGAGEMENT MARKING (OPTIONAL)



ISAT - PRPIP 3812

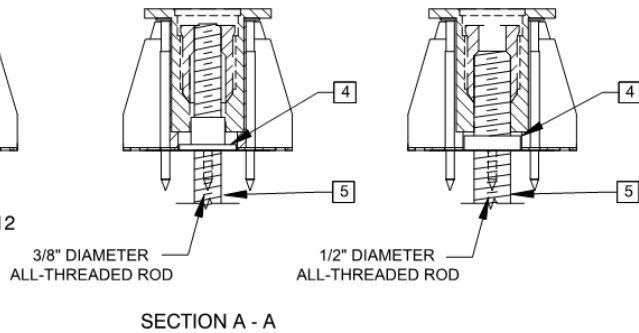
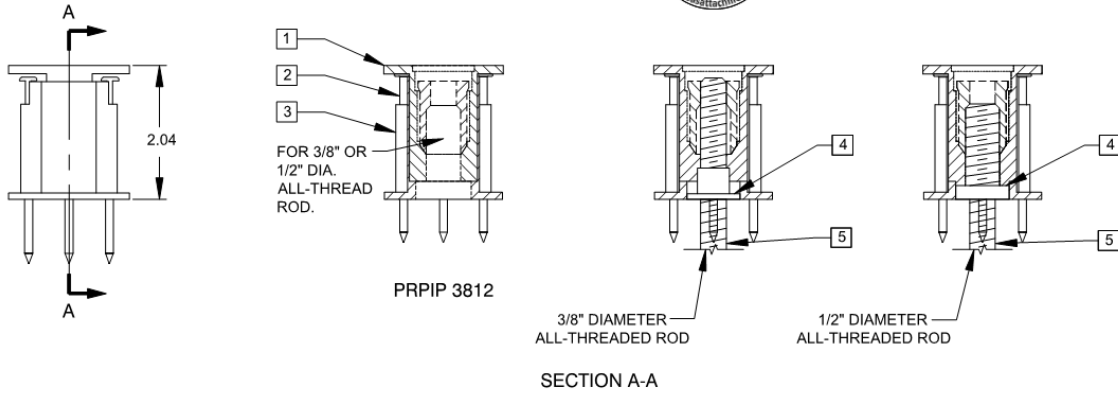
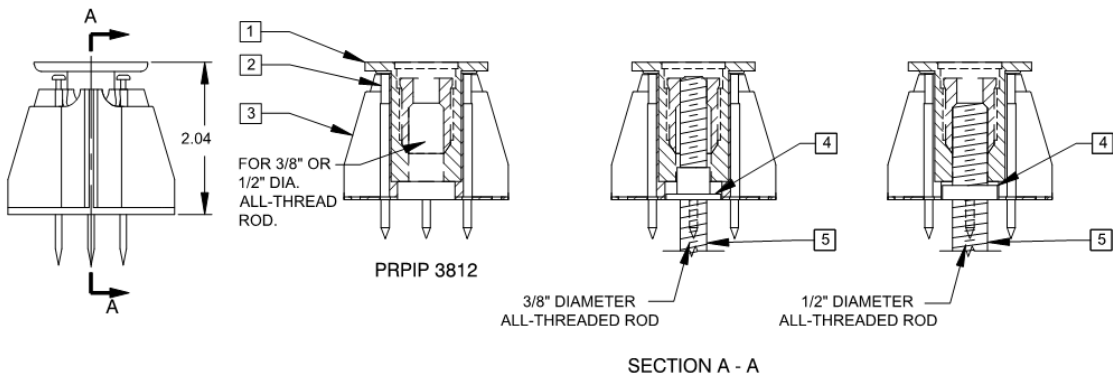


FIGURE 1A—ISAT-PRPIP3812 CAST-IN-PLACE INSERTS FOR FORM POUR CONCRETE (TOP—STANDARD BASE; BOTTOM—WIDE BASE)

- 1 HEADED BARREL: CARBON STEEL
- 2 NAIL: CARBON STEEL
- 3 PLASTIC SLEEVE: POLYPROPYLENE
- 4 ENGAGEMENT MARKING (OPTIONAL)
- 5 ALL THREADED ROD W/ INTEGRAL ENGAGEMENT MARKING (OPTIONAL)

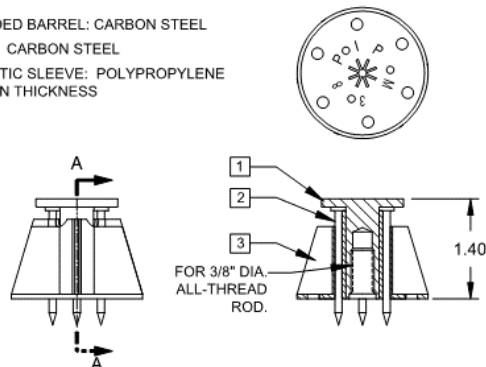


- 1 HEADED BARREL: CARBON STEEL
- 2 NAIL: CARBON STEEL
- 3 PLASTIC SLEEVE: POLYPROPYLENE
- 4 ENGAGEMENT MARKING (OPTIONAL)
- 5 ALL THREADED ROD W/ INTEGRAL ENGAGEMENT MARKING (OPTIONAL)



**FIGURE 1B—PRPIP3812 CAST-IN-PLACE INSERTS FOR FORM POUR CONCRETE (TOP—STANDARD BASE; BOTTOM—WIDE BASE)**

- 1 HEADED BARREL: CARBON STEEL
- 2 NAIL: CARBON STEEL
- 3 PLASTIC SLEEVE: POLYPROPYLENE 0.06 IN THICKNESS



**FIGURE 1C—PIM38 CAST-IN-PLACE INSERTS FOR FORM POUR CONCRETE**

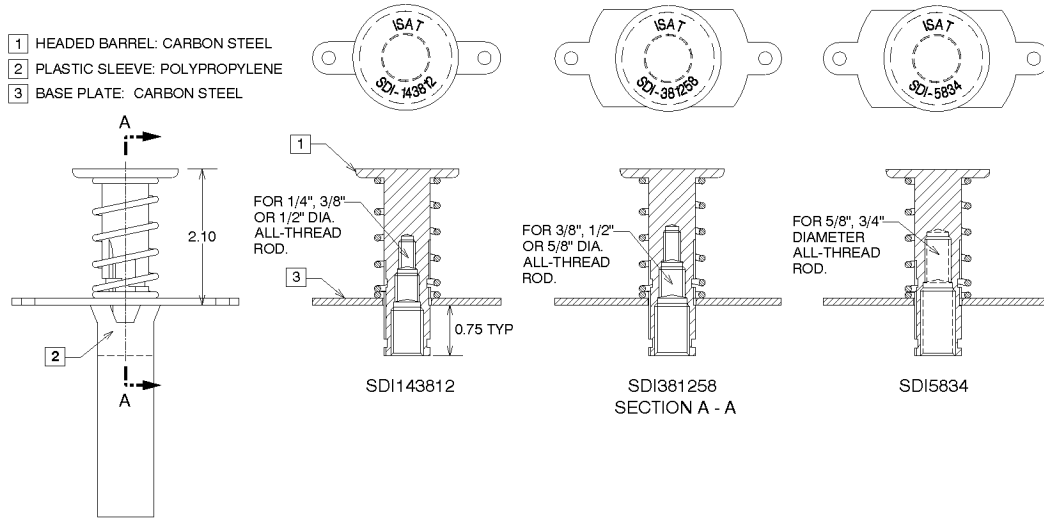


FIGURE 2—SDI CAST-IN-PLACE INSERTS FOR CONCRETE OVER METAL DECKS

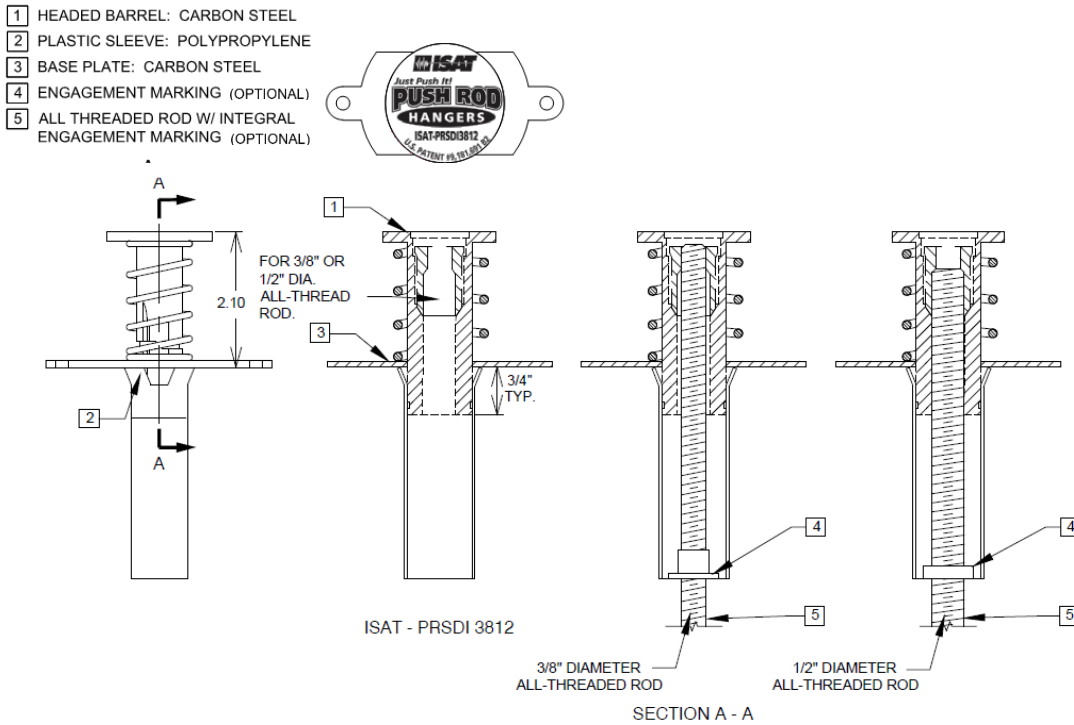


FIGURE 2A—ISAT-PRSDI3812 CAST-IN-PLACE INSERTS FOR CONCRETE OVER METAL DECKS

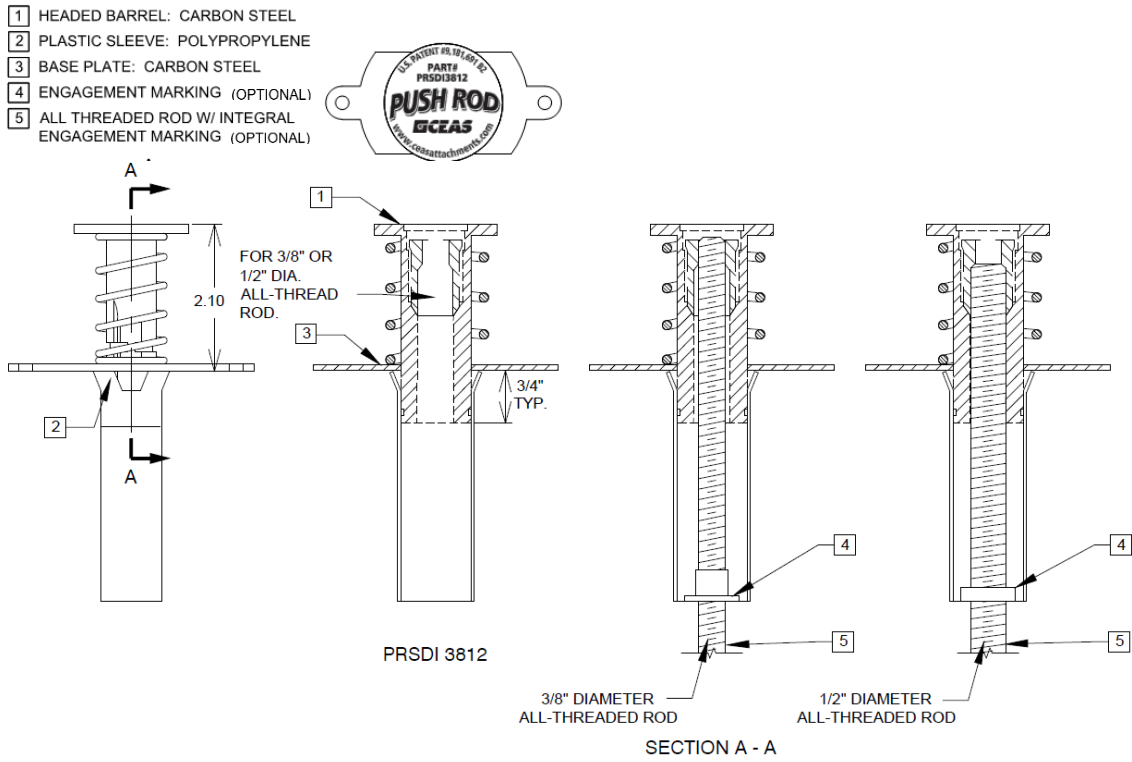


FIGURE 2B—PRSDI3812 CAST-IN-PLACE INSERTS FOR CONCRETE OVER METAL DECKS

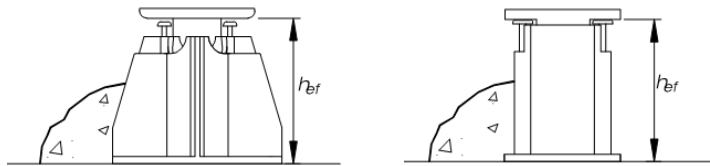
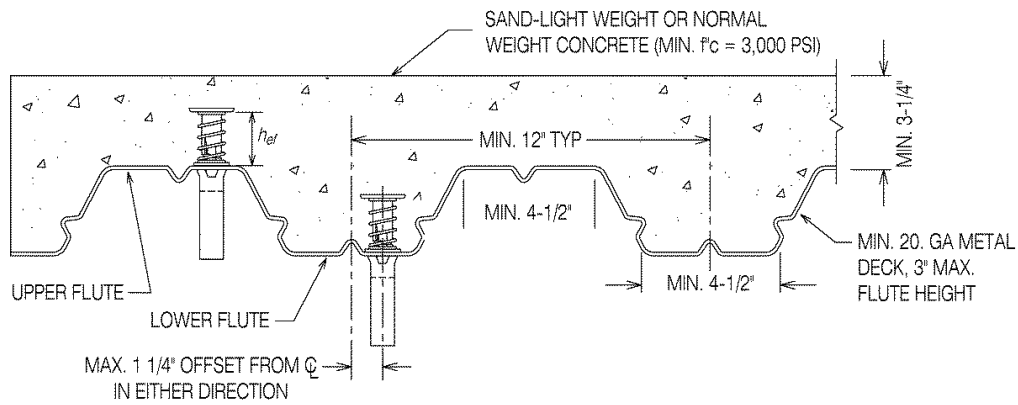


FIGURE 3—PIP AND ISAT-PRPIP3812 (PRPIP3812) INSERTS INSTALLED IN SOFFIT OF FORM POUR CONCRETE FLOOR AND ROOF ASSEMBLIES (LEFT—WIDE BASE; RIGHT—STANDARD BASE)



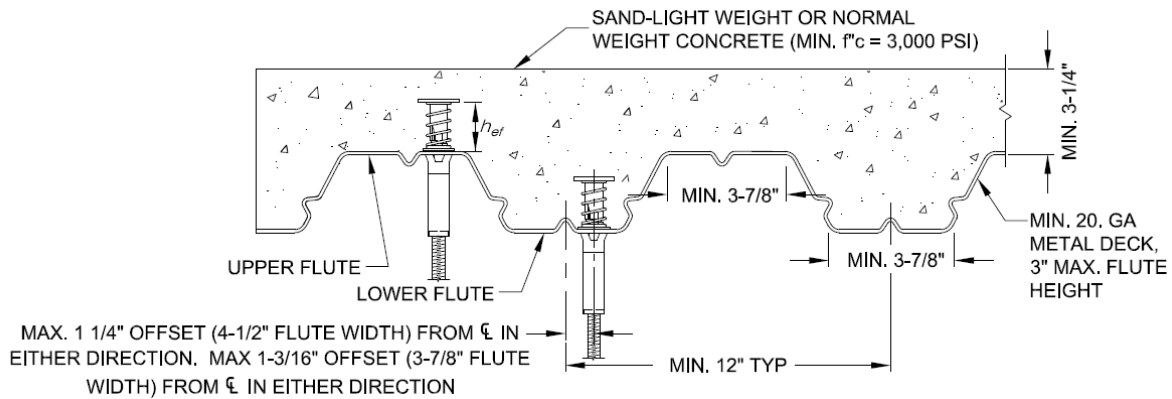
**FIGURE 4—SDI INSERTS INSTALLED IN SOFFIT OF CONCRETE OVER METAL DECK FLOOR AND ROOF ASSEMBLIES<sup>1,2,3,4</sup>**

<sup>1</sup>Deck inserts may be placed in the upper flute or lower flute of the steel deck assembly. Upper flute installations require a minimum  $\frac{3}{4}$ " concrete cover above the head of the insert. Inserts in the lower flute may be installed with a maximum  $\frac{1}{4}$ " offset in either direction from the center of the flute. Inserts in upper flute may be installed anywhere across upper flute.

<sup>2</sup>Axial spacing along the flute length shall be minimum  $3h_{ef}$ .

<sup>3</sup>Upper flute SDI inserts not subject to metal pan deck dimension limitations or minimum gauge (tension only) limitations.

<sup>4</sup>Lower flute installations in flute widths less than  $4\frac{1}{2}$ " allowed if the following three conditions are met: 1) the application is limited to tension only; 2) insert meets cover requirements in ACI 318-19 Section 20.5.1, ACI 318-14 Section 20.6.1 or ACI 318-11, Section 7.7; 3) applicable edge effects ( $\psi_{ed,N}$ ) are considered.



**FIGURE 4A—ISAT-PRSDI8312 (PRSDI3812) INSERTS INSTALLED IN SOFFIT OF CONCRETE OVER METAL DECK FLOOR AND ROOF ASSEMBLIES<sup>1,2,3,4</sup>**

<sup>1</sup>Deck inserts may be placed in the upper flute or lower flute of the steel deck assembly. Upper flute installations require a minimum  $\frac{3}{4}$ " concrete cover above the head of the insert. Inserts in the lower flute may be installed with a maximum offset, as shown in [Figure 4A](#), in either direction from the center of the flute. Inserts in upper flute may be installed anywhere across upper flute.

<sup>2</sup>Axial spacing along the flute length shall be minimum  $3h_{ef}$ .

<sup>3</sup>Upper flute PRSDI inserts not subject to metal pan deck dimension limitations or minimum gauge (tension only) limitations.

<sup>4</sup>Lower flute installations in flute widths less than  $3\frac{7}{8}$ " allowed if the following three conditions are met: 1) the application is limited to tension only; 2) insert meets cover requirements in ACI 318-19 Section 20.5.1, ACI 318-14 Section 20.6.1 or ACI 318-11, Section 7.7; 3) applicable edge effects ( $\psi_{ed,N}$ ) are considered.

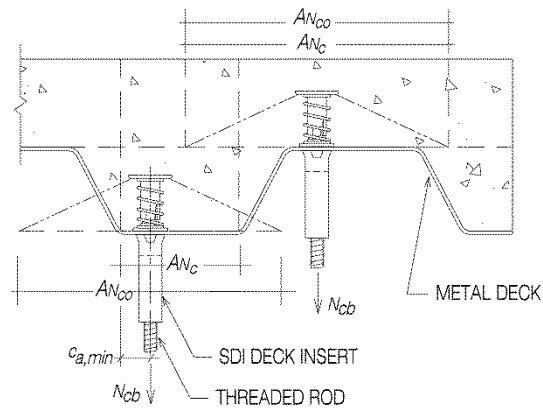


FIGURE 5 —IDEALIZATION OF CONCRETE ON DECK FOR DETERMINATION OF CONCRETE BREAKOUT STRENGTH IN ACCORDANCE WITH ACI 318



TABLE 2—PIP ANCHOR DESIGN INFORMATION<sup>1,2,3,4,5,6,7,8</sup>

DESIGN INFORMATION	SYMBOL	UNITS	PIP38			PIP143812-2			PIP381258-2			PIP5834-2	
Nominal All Threaded Rod diameter	-	in.	<sup>3</sup> / <sub>8</sub>	<sup>1</sup> / <sub>4</sub>	<sup>3</sup> / <sub>8</sub>	<sup>1</sup> / <sub>2</sub>	<sup>3</sup> / <sub>8</sub>	<sup>1</sup> / <sub>2</sub>	<sup>3</sup> / <sub>8</sub>	<sup>5</sup> / <sub>8</sub>	<sup>3</sup> / <sub>4</sub>		
Insert O.D.	$d_a$	in. (mm)	0.510 (12.95)		0.811 (20.6)			1.000 (25.4)				1.102 (28.0)	
Effective embedment depth	$h_{ef}$	in. (mm)	1.27 (32.3)		1.875 (47.6)			1.954 (49.6)				1.875 (47.6)	
Insert steel characterization	-	-	Ductile		Non-ductile			Non-ductile				Non-ductile	
Modification factor for tension strength in uncracked concrete	$\psi_{C,N}$	-	1.25		1.25			1.25				1.25	
Nominal tension strength of single insert in tension as governed by steel strength	$N_{sa,insert}$	lb (kN)	3,020 (13.4)	3,565 (15.9)	5,625 (25.0)	8,415 (37.4)	9,090 (40.4)	5,020 (22.3)	16,755 (74.5)	18,620 (82.8)	18,685 (83.1)		
Nominal seismic tension strength of single insert in tension as governed by steel strength	$N_{sa,insert,eq}$	lb (kN)	3,020 (13.4)	3,565 (15.9)	5,625 (25.0)	8,415 (37.4)	9,090 (40.4)	5,020 (22.3)	16,755 (74.5)	18,620 (82.8)	18,685 (83.1)		
Nominal steel shear strength of single insert	$V_{sa}$	lb (kN)	2,415 (10.7)	N/A <sup>9</sup>	N/A <sup>9</sup>	6,810 (30.3)	N/A <sup>9</sup>	N/A <sup>9</sup>	8,210 (36.5)	N/A <sup>9</sup>	8,760 (39.0)		
Nominal steel shear strength of single insert for seismic loading	$V_{sa,eq}$	lb (kN)	2,415 (10.7)	N/A <sup>9</sup>	N/A <sup>9</sup>	6,810 (30.3)	N/A <sup>9</sup>	N/A <sup>9</sup>	8,210 (36.5)	N/A <sup>9</sup>	8,760 (39.0)		

For SI: 1 inch = 25.4 mm, 1 pound = 4.45 N, 1 psi = 0.006895 MPa. For pound-inch unit: 1 mm = 0.03937 inches.

<sup>1</sup>Concrete must be normal weight concrete with  $f'_c$  of 3,000 psi minimum. Installation must comply with Sections 4.1.10 and 4.3, and [Figure 6](#) of this report.

<sup>2</sup>Only the largest size of threaded rod specified for each insert must be used for applications resisting shear loads.

<sup>3</sup>Design of headed cast-in specialty inserts shall be in accordance with the provisions of ACI 318 (-19 or -14) Chapter 17 or ACI 318-11 Appendix D for cast-in headed anchors. The value of  $k_c$  shall be in accordance with the value for cast-in anchors in ACI 318-19 17.6.2.2, ACI 318-14 17.4.2.2 or ACI 318-11 D.5.2.2.

<sup>4</sup>Strength reduction factors shall be taken from ACI 318-19 17.5.3, ACI 318-14 17.3.3 or ACI 318-11 D.4.3 for cast-in headed anchors.

<sup>5</sup>Strength reduction factor for load combinations of ACI 318 (-19 or -14) 5.3 or ACI 318-11 9.2 governed by steel strength shall be taken as 0.65 for tension and 0.60 for shear.

<sup>6</sup>The concrete tension strength of headed cast-in specialty inserts shall be calculated in accordance with ACI 318 (-19 or -14) Chapter 17 or ACI 318-11 Appendix D and [Figure 1](#).

<sup>7</sup>Insert OD is the outside diameter of the plastic sleeve.

<sup>8</sup>The strengths shown in the table are for inserts only. Design professional is responsible for checking threaded rod strength in tension, shear, and combined tension and shear, as applicable.

<sup>9</sup>N/A = Not Applicable for shear applications.

TABLE 2A—ISAT-PRPIP3812 ANCHOR DESIGN INFORMATION<sup>1,2,3,4,5,6,7,8</sup>

DESIGN INFORMATION	SYMBOL	UNITS	ISAT-PRPIP3812	
			<sup>3</sup> / <sub>8</sub>	<sup>1</sup> / <sub>2</sub>
Nominal All Threaded Rod diameter (in.) and Installation Condition	-	in.	<sup>3</sup> / <sub>8</sub>	<sup>1</sup> / <sub>2</sub>
Insert O.D.	$d_a$	in. (mm)	1.120 (28.4)	
Insert effective embedment depth	$h_{ef}$	in. (mm)	1.954 (49.6)	
Insert steel characterization	-	-	Ductile	
Modification factor for tension strength in uncracked concrete	$\psi_{C,N}$	-	1.25	
Nominal tension strength of single insert in tension as governed by steel strength	$N_{sa,insert}$	lb (kN)	3,910 (17.4)	7,220 (32.1)
Nominal seismic tension strength of single insert in tension as governed by steel strength	$N_{sa,insert,eq}$	lb (kN)	3,910 (17.4)	7,220 (32.1)
Nominal steel shear strength of single insert	$V_{sa}$	lb (kN)	N/A <sup>9</sup>	4,370 (19.4)
Nominal steel shear strength of single insert for seismic loading	$V_{sa,eq}$	lb (kN)	N/A <sup>9</sup>	4,370 (19.4)

For SI: 1 inch = 25.4 mm, 1 pound = 4.45 N, 1 psi = 0.006895 MPa. For pound-inch unit: 1 mm = 0.03937 inches.

<sup>1</sup>Concrete must be normal weight concrete with  $f'_c$  of 3,000 psi minimum. Installation must comply with Sections 4.1.10 and 4.3, and [Figure 6A](#) of this report.

<sup>2</sup>Only the largest size of threaded rod specified for each insert must be used for applications resisting shear loads.

<sup>3</sup>Design of headed cast-in specialty inserts shall be in accordance with the provisions of ACI 318 (-19 or -14) Chapter 17 or ACI 318-11 Appendix D for cast-in headed anchors. The value of  $k_c$  shall be in accordance with the value for cast-in anchors in ACI 318-19 17.6.2.2, ACI 318-14 17.4.2.2 or ACI 318-11 D.5.2.2.

<sup>4</sup>Strength reduction factors shall be taken from ACI 318-19 17.5.3, ACI 318-14 17.3.3 or ACI 318-11 D.4.3 for cast-in headed anchors.

<sup>5</sup>Strength reduction factors shall be taken from ACI 318-19 17.5.3, ACI 318-14 17.3.3 or ACI 318-11 D.4.3, as applicable, for steel elements. Strength reduction factor for load combinations of ACI 318 (-19 or -14) 5.3 or ACI 318-11 9.2, as applicable, governed by steel strength of ductile steel elements shall be taken as 0.75 for tension and 0.65 for shear.

<sup>6</sup>The concrete tension strength of headed cast-in specialty inserts shall be calculated in accordance with ACI 318 (-19 or -14) Chapter 17 or ACI 318-11 Appendix D and [Figure 2](#).

<sup>7</sup>Insert OD is the outside diameter of the plastic sleeve.

<sup>8</sup>The strengths shown in the table are limited to ISAT-PRPIP3812 inserts with ASTM A307 Grade A threaded rods (or materially equivalent). Design professional is responsible for checking threaded rod strength in tension, shear, and combined tension and shear, as applicable.

<sup>9</sup>N/A = Not Applicable for shear applications.

TABLE 3—SDI ANCHOR DESIGN INFORMATION<sup>1,2,3,4,5,6,8</sup>

DESIGN INFORMATION	SYMBOL	UNITS	SDI143812 <sup>9</sup>			SDI381258			SDI5834	
			<sup>1</sup> / <sub>4</sub>	<sup>3</sup> / <sub>8</sub>	<sup>1</sup> / <sub>2</sub>	<sup>3</sup> / <sub>8</sub>	<sup>1</sup> / <sub>2</sub>	<sup>5</sup> / <sub>8</sub>	<sup>5</sup> / <sub>8</sub>	<sup>3</sup> / <sub>4</sub>
Nominal All Threaded Rod diameter	-	in.	<sup>1</sup> / <sub>4</sub>	<sup>3</sup> / <sub>8</sub>	<sup>1</sup> / <sub>2</sub>	<sup>3</sup> / <sub>8</sub>	<sup>1</sup> / <sub>2</sub>	<sup>5</sup> / <sub>8</sub>	<sup>5</sup> / <sub>8</sub>	<sup>3</sup> / <sub>4</sub>
Insert O.D. <sup>7</sup>	$d_a$	in. (mm)	0.940 (23.9)			1.160 (29.5)			1.290 (32.8)	
Effective embedment depth	$h_{ef}$	in. (mm)	1.980 (50.3)			1.980 (50.3)			1.980 (50.3)	
Insert steel characterization	-	-	Non-ductile			Non-ductile			Non-ductile	
Modification factor for tension strength in uncracked concrete	$\psi_{C,N}$	-	1.25			1.25			1.25	
Nominal tension strength of single insert in tension as governed by steel strength	$N_{sa,insert}$	lb (kN)	2,325 (10.3)	8,655 (38.5)	10,085 (44.9)	5,655 (25.2)	9,136 (40.6)	16,655 (74.1)	18,730 (83.3)	14,200 (63.2)
Nominal seismic tension strength of single insert in tension as governed by steel strength	$N_{sa,insert,eq}$	lb (kN)	2,325 (10.3)	8,655 (38.5)	10,085 (44.9)	5,655 (25.2)	9,136 (40.6)	16,655 (74.1)	18,730 (83.3)	14,200 (63.2)
Nominal steel shear strength of single insert in the soffit of concrete on metal deck, lower flute	$V_{sa,deck,lower}$	lb (kN)	N/A <sup>10</sup>	N/A <sup>10</sup>	3,105 (13.8)	N/A <sup>10</sup>	N/A <sup>10</sup>	2,610 (11.6)	N/A <sup>10</sup>	3,345 (14.9)
Nominal steel shear strength of single insert in the soffit of concrete on metal deck, upper flute	$V_{sa,deck,upper}$	lb (kN)	N/A <sup>10</sup>	N/A <sup>10</sup>	3,500 (15.6)	N/A <sup>10</sup>	N/A <sup>10</sup>	1,710 (7.6)	N/A <sup>10</sup>	5,565 (24.8)
Nominal steel shear strength of single insert in the soffit of concrete on metal deck, for seismic loading, lower flute	$V_{sa,deck,lower,eq}$	lb (kN)	N/A <sup>10</sup>	N/A <sup>10</sup>	3,105 (13.8)	N/A <sup>10</sup>	N/A <sup>10</sup>	2,610 (11.6)	N/A <sup>10</sup>	3,345 (14.9)
Nominal steel shear strength of single insert in the soffit of concrete on metal deck, for seismic loading, upper flute	$V_{sa,deck,upper,eq}$	lb (kN)	N/A <sup>10</sup>	N/A <sup>10</sup>	3,500 (15.6)	N/A <sup>10</sup>	N/A <sup>10</sup>	1,710 (7.6)	N/A <sup>10</sup>	5,565 (24.8)

For SI: 1 inch = 25.4 mm, 1 pound = 4.45 N, 1 psi = 0.006895 MPa. For pound-inch unit: 1 mm = 0.03937 inches.

<sup>1</sup>Concrete must be normal weight or lightweight concrete with  $f_c$  of 3,000 psi minimum. Installation must comply with Sections 4.1.10 and 4.3, and Figure 7 of this report.

<sup>2</sup>Only the largest size of the threaded rod specified for each insert must be used for applications resisting shear loads.

<sup>3</sup>Design of headed cast-in specialty inserts shall be in accordance with the provisions of ACI 318 (-19 or -14) Chapter 17 or ACI 318-11 Appendix D for cast-in headed anchors. The value of  $k_c$  shall be in accordance with the value for cast-in anchors in ACI 318-19 17.6.2.2, ACI 318-14 17.4.2.2 or ACI 318-11 D.5.2.2.

<sup>4</sup>Strength reduction factors shall be taken from ACI 318-19 17.5.3, ACI 318-14 17.3.3 or ACI 318-11 D.4.3 for cast-in headed anchors.

<sup>5</sup>Strength reduction factor for load combinations of ACI 318 (-19 or -14) 5.3 or ACI 318-11 Section 9.2 governed by steel strength shall be taken as 0.65 for tension and 0.60 for shear.

<sup>6</sup>The concrete tension strength of headed cast-in specialty inserts in the soffit of concrete on metal deck assemblies shall be calculated in accordance with ACI 318 (-19 or -14) Chapter 17 or ACI 318-11 Appendix D and Figure 5.

<sup>7</sup>Insert OD is the outside diameter of the spring.

<sup>8</sup>The strengths shown in the table are for inserts only. Design professional is responsible for checking threaded rod strength in tension, shear, combined tension, and shear, and with the influence of bending on tension values when loaded in shear, as applicable.

<sup>9</sup>Threaded rods used with the SDI143812 in tension shall have maximum tensile strengths,  $f_{uta}$ , as follows: <sup>1</sup>/<sub>2</sub>-inch diameter 60,000 psi (415 MPa).

<sup>10</sup>N/A = Not Applicable for shear applications.

TABLE 3A—ISAT-PRSDI3812 ANCHOR DESIGN INFORMATION<sup>1,2,3,4,5,6,8</sup>

DESIGN INFORMATION	SYMBOL	UNITS	ISAT-PRSDI3812	
Nominal All Threaded Rod diameter (inch) and Installation Condition	-	in.	<sup>3</sup> / <sub>8</sub>	<sup>1</sup> / <sub>2</sub>
Insert O.D. <sup>7</sup>	$d_a$	in. (mm)	1.243 (31.6)	
Effective embedment depth	$h_{ef}$	in. (mm)	1.980 (50.3)	
Insert steel characterization	-	-	Ductile	
Modification factor for insert tension strength in uncracked concrete	$\psi_{C,N}$	-	1.25	
Nominal tension strength of single insert in tension as governed by steel strength	$N_{sa,insert}$	lb (kN)	2,275 (10.1)	7,930 (35.3)
Nominal seismic tension strength of single insert in tension as governed by steel strength	$N_{sa,insert,eq}$	lb (kN)	2,275 (10.1)	7,930 (35.3)
Nominal steel shear strength of single insert in the soffit of concrete on metal deck, lower flute	$V_{sa,deck,lower}$	lb (kN)	N/A <sup>9</sup>	2,380 (10.6)
Nominal steel shear strength of single insert in the soffit of concrete on metal deck, for seismic loading, lower flute	$V_{sa,deck,lower,eq}$	lb (kN)	N/A <sup>9</sup>	2,380 (10.6)
Nominal steel shear strength of single insert in the soffit of concrete on metal deck, upper flute	$V_{sa,deck,upper}$	lb (kN)	N/A <sup>9</sup>	4,370 (19.4)
Nominal steel shear strength of single insert in the soffit of concrete on metal deck, for seismic loading, upper flute	$V_{sa,deck,upper,eq}$	lb (kN)	N/A <sup>9</sup>	4,370 (19.4)

For SI: 1 inch = 25.4 mm, 1 pound = 4.45 N, 1 psi = 0.006895 MPa. For pound-inch unit: 1 mm = 0.03937 inches.

<sup>1</sup>Concrete must be normal weight or sand-lightweight concrete with  $f'_c$  of 3,000 psi minimum. Installation must comply with Sections 4.1.10 and 4.3, and Figure 7A of this report.

<sup>2</sup>Only the largest size of the threaded rod specified for each insert must be used for applications resisting shear loads.

<sup>3</sup>Design of headed cast-in specialty inserts shall be in accordance with the provisions of ACI 318 (-19 or -14) Chapter 17 or ACI 318-11 Appendix D for cast-in headed anchors. The value of  $k_c$  shall be in accordance with the value for cast-in anchors in ACI 318-19 17.6.2.2, ACI 318-14 17.4.2.2 or ACI 318-11 D.5.2.2.

<sup>4</sup>Strength reduction factors shall be taken from ACI 318-19 17.5.3, ACI 318-14 17.3.3 or ACI 318-11 D.4.3 for cast-in headed anchors.

<sup>5</sup>Strength reduction factors shall be taken from ACI 318-19 17.5.3, ACI 318-14 17.3.3 or ACI 318-11 D.4.3, as applicable, for steel elements. Strength reduction factor for load combinations of ACI 318 (-19 or -14) 5.3 or ACI 318-11 9.2, as applicable, governed by steel strength of ductile steel elements shall be taken as 0.75 for tension and 0.65 for shear.

<sup>6</sup>The concrete tension strength of headed cast-in specialty inserts in the soffit of concrete on metal deck assemblies shall be calculated in accordance with ACI 318 (-19 or -14) Chapter 17 or ACI 318-11 Appendix D and Figure 5.

<sup>7</sup>Insert OD is the outside diameter of the spring.

<sup>8</sup>The strengths shown in the table are limited to ISAT-PRSDI3812 inserts with ASTM A307 Grade A (or materially equivalent). Design professional is responsible for checking threaded rod strength in tension, shear, combined tension, and shear, and with the influence of bending on tension values when loaded in shear, as applicable.

<sup>9</sup>N/A = Not Applicable for shear applications.

TABLE 4—EXAMPLE ASD ALLOWABLE TENSION DESIGN VALUES FOR ILLUSTRATIVE PURPOSES<sup>1,2,3,4,5,6,7,8,9,10,11,12</sup>

THREADED ROD DIAMETER (in.)	PIPM38 (lbs)	PIP143812-2 (lbs)	PIP381258-2 (lbs)	PIP5834-2 (lbs)	SDI143812 (lbs)	SDI381258 (lbs)	SDI5834 (lbs)
<sup>1</sup> / <sub>4</sub>	NA	1,820	NA	NA	985	NA	NA
<sup>3</sup> / <sub>8</sub>	1,035	1,820	1,935	NA	985	985	NA
<sup>1</sup> / <sub>2</sub>	NA	1,820	1,935	NA	985	985	NA
<sup>5</sup> / <sub>8</sub>	NA	NA	1,935	1,820	NA	985	985
<sup>3</sup> / <sub>4</sub>	NA	NA	NA	1,820	NA	NA	985

For SI: 1 pound = 4.45 N, 1 psi = 0.00689 MPa, 1 psi = 0.00689 MPa. For pound-inch unit: 1 inch = 25.4 mm.

<sup>1</sup>Concrete  $f'_c$  = 3000 psi normal weight concrete for PIP anchors;  $f'_c$  = 3000 psi light weight or normal concrete for SDI anchors at lower flute.

<sup>2</sup>Single anchors with static tension load. Installation must be in accordance with Figure 3 for PIP inserts and Figure 4 for SDI anchors.

<sup>3</sup>Concrete determined to remain uncracked for the life of the anchorage.

<sup>4</sup>Load combinations from ACI 318 (-19 or -14) 5.3 or ACI 318-11 9.2 (no seismic loading).

<sup>5</sup>30% dead load and 70% live load, controlling load combination 1.2D + 1.6 L.

<sup>6</sup>Calculation of the weighted average for  $\alpha = 0.3 \cdot 1.2 + 0.7 \cdot 1.6 = 1.48$ .

<sup>7</sup>Assuming no edge distance influence with  $\psi_{ed,N} = 1.0$  and no side-face blowout in tension for PIP and upper flute SDI anchors.

<sup>8</sup>Edge distance  $\psi_{ed,N} = 0.7 + 0.3c_{a,min}/1.5h_{ef} = 0.8$  for lower flute SDI anchors, see Figure 5.

<sup>9</sup> $h \geq h_{min}$  according to ACI 318-19 17.9, ACI 318-14 17.7 or ACI 318-11 D.8.

<sup>10</sup>Values are for Condition B where supplementary reinforcement in accordance with ACI 318-19 17.5.3, ACI 318-14 17.3.3 or ACI 318-11 D.4.3 is not provided.

<sup>11</sup>NA (not applicable) denotes that this value is not applicable for design.

<sup>12</sup>The allowable loads shown in the table are for inserts only. For PIP anchors, design professional is responsible for checking threaded rod strength in tension, shear, and combined tension and shear, as applicable. For SDI anchors, design professional is responsible for checking threaded rod in tension, shear, and with the influence of bending on tension values when loaded in shear, additionally.

TABLE 5—EXAMPLE ASD ALLOWABLE SHEAR DESIGN VALUE FOR ILLUSTRATIVE PURPOSES<sup>1,2,3,4,5,6,7,8,9,10,11,12</sup>

THREADED ROD DIAMETER (in.)	PIPM38 (lbs)	PIP143812-2 (lbs)	PIP381258-2 (lbs)	PIP5834-2 (lbs)	SDI143812 (lbs)	SDI381258 (lbs)	SDI5834 (lbs)
¼	NA	NA	NA	NA	NA	NA	NA
⅜	1,035	NA	NA	NA	NA	NA	NA
½	NA	1,820	NA	NA	1,260	NA	NA
⅝	NA	NA	1,940	NA	NA	1,060	NA
¾	NA	NA	NA	1,820	NA	NA	1,355

For SI: 1 pound = 4.45 N, 1 psi = 0.00689 MPa, 1 psi = 0.00689 MPa. For pound-inch unit: 1 inch = 25.4 mm.

<sup>1</sup>Concrete  $f_c = 3000$  psi normal weight concrete for PIP anchors;  $f_c = 3000$  psi light weight or normal concrete for SDI anchors at lower flute.

<sup>2</sup>Single anchors with static shear load. Installation must be in accordance with [Figure 3](#) for PIP anchors and [Figure 4](#) for SDI anchors.

<sup>3</sup>For shear application, the largest size of threaded rod specified for each insert must be used.

<sup>4</sup>Concrete determined to remain uncracked for the life of the anchorage.

<sup>5</sup>Load combinations from ACI 318 (-19 or -14) 5.3 or ACI 318-11 9.2 (no seismic loading).

<sup>6</sup>30% dead load and 70% live load, controlling load combination 1.2D + 1.6 L.

<sup>7</sup>Calculation of the weighted average for  $\alpha = 0.3 \cdot 1.2 + 0.7 \cdot 1.6 = 1.48$ .

<sup>8</sup>Assuming no need for checking concrete breakout in shear for PIP with edge distance  $c_{a1}$  larger enough so  $V_b$  does not control.

<sup>9</sup> $h \geq h_{min}$  according to ACI 318-19 17.9, ACI 318-14 17.7 or ACI 318-11 D.8.

<sup>10</sup>Values are for Condition B where supplementary reinforcement in accordance with ACI 318-19 17.5.3, ACI 318-14 17.3.3 or ACI 318-11 D.4.3 is not provided.

<sup>11</sup>NA (Not applicable) denotes that this value is not applicable for design.

<sup>12</sup>The allowable loads shown in the table are for inserts only. For PIP anchors, design professional is responsible for checking threaded rod strength in tension, shear, and combined tension and shear, as applicable. For SDI anchors, design professional is responsible for checking threaded rod strength in tension, shear, combined tension, and shear, and with the influence of bending on tension values when loaded in shear, as applicable.

TABLE 6—EXAMPLE ASD ALLOWABLE TENSION DESIGN VALUE FOR ILLUSTRATIVE PURPOSES<sup>1,2,3,4,5,6,7,8,9,10,11</sup>

THREADED ROD DIAMETER (in.)	ISAT-PRPIP3812 (lbs)	ISAT-PRSDI3812 (lbs)
⅜	1,698	840
½	1,698	840

For SI: 1 pound = 4.45 N, 1 psi = 0.00689 MPa, 1 psi = 0.00689 MPa. For pound-inch unit: 1 inch = 25.4 mm.

<sup>1</sup>Concrete  $f_c = 3,000$  psi normal weight concrete for ISAT-PRPIP3812 anchors;  $f_c = 3,000$  psi light weight or normal concrete for ISAT-PRSDI3812 anchors at lower flute.

<sup>2</sup>Single anchors with static tension load. Installation must be in accordance with [Figure 3](#) for ISAT-PRPIP3812 inserts and [Figure 4A](#) for ISAT-PRSDI3812 anchors.

<sup>3</sup>Concrete determined to remain uncracked for the life of the anchorage.

<sup>4</sup>Load combinations from ACI 318 (-19 or -14) 5.3 or ACI 318-11 9.2 (no seismic loading).

<sup>5</sup>30% dead load and 70% live load, controlling load combination 1.2D + 1.6 L.

<sup>6</sup>Calculation of the weighted average for  $\alpha = 0.3 \cdot 1.2 + 0.7 \cdot 1.6 = 1.48$ .

<sup>7</sup>Assuming no edge distance influence with  $\psi_{ed,N} = 1.0$  and no side-face blowout in tension for ISAT-PRPIP3812 and upper flange ISAT-PRSDI3812 anchors.

<sup>8</sup>Edge distance  $\psi_{ed,N} = 0.7 + 0.3c_{a,min}/1.5h_{ef} = 0.8$  for lower flange ISAT-PRSDI3812 anchors, see [Figure 5](#).

<sup>9</sup> $h \geq h_{min}$  according to ACI 318-19 17.9, ACI 318-14 17.7 or ACI 318-11 D.8.

<sup>10</sup>Values are for Condition B where supplementary reinforcement in accordance with ACI 318-19 17.5.3, ACI 318-14 17.3.3 or ACI 318-11 D.4.3 is not provided.

<sup>11</sup>The allowable loads shown in the table are for inserts only. For ISAT-PRPIP3812 anchors, design professional is responsible for checking threaded rod strength in tension, shear, and combined tension and shear, as applicable. For ISAT-PRSDI3812 anchors, design professional is responsible for checking threaded rod in tension, shear, and with the influence of bending on tension values when loaded in shear, additionally.

TABLE 7—EXAMPLE ASD ALLOWABLE SHEAR DESIGN VALUE FOR ILLUSTRATIVE PURPOSES<sup>1,2,3,4,5,6,7,8,9,10,11,12</sup>

THREADED ROD DIAMETER (in.)	ISAT-PRPIP3812 (lbs)	ISAT-PRSDI3812 (lbs)
3/8	N/A	N/A
1/2	1,698	965

For SI: 1 pound = 4.45 N, 1 psi = 0.00689 MPa, 1 psi = 0.00689 MPa. For pound-inch unit: 1 inch = 25.4 mm.

<sup>1</sup>Concrete  $f'_c = 3,000$  psi normal weight concrete for PIP anchors;  $f'_c = 3,000$  psi light weight or normal concrete for SDI anchors at lower flute.

<sup>2</sup>Single anchors with static shear load. Installation must be in accordance to [Figure 3](#) for ISAT-PRPIP3812 anchors and [Figure 4A](#) for ISAT-PRSDI3812 anchors.

<sup>3</sup>For shear application, the largest size of threaded rod specified for each insert must be used.

<sup>4</sup>Concrete determined to remain uncracked for the life of the anchorage.

<sup>5</sup>Load combinations from ACI 318 (-19 or -14) 5.3 or ACI 318-11 9.2 (no seismic loading).

<sup>6</sup>30% dead load and 70% live load, controlling load combination 1.2D + 1.6 L.

<sup>7</sup>Calculation of the weighted average for  $\alpha = 0.3 \cdot 1.2 + 0.7 \cdot 1.6 = 1.48$ .

<sup>8</sup>Assuming no need for checking concrete breakout in shear for ISAT-PRPIP3812 with edge distance  $c_{a1}$  larger enough so  $V_b$  does not control.

<sup>9</sup> $h \geq h_{min}$  according to ACI 318-19 17.9, ACI 318-14 17.7 or ACI 318-11 D.8.

<sup>10</sup>Values are for Condition B where supplementary reinforcement in accordance with ACI 318-19 17.5.3, ACI 318-14 17.3.3 or ACI 318-11 D.4.3 is not provided.

<sup>11</sup>N/A (Not applicable) denotes that this value is not applicable for design.

<sup>12</sup>The allowable loads shown in the table are for inserts only. For ISAT-PRPIP3812 anchors, design professional is responsible for checking threaded rod strength in tension, shear, and combined tension and shear, as applicable. For ISAT-PRSDI3812 anchors, design professional is responsible for checking threaded rod strength in tension, shear, combined tension, and shear, and with the influence of bending on tension values when loaded in shear, as applicable.



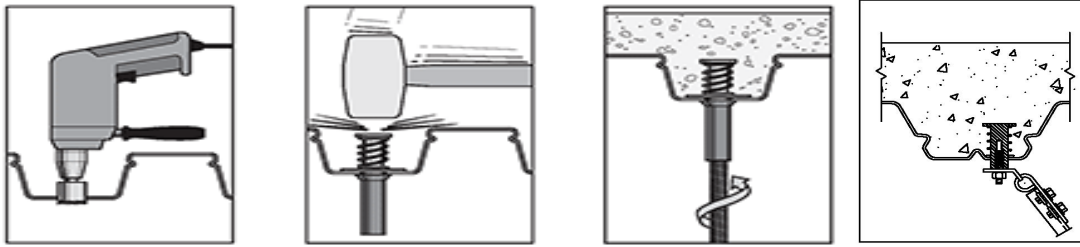
1. Position on wood form. Impact PIP driving nails all the way into wood until plastic base sits flush and tight against form. 2. After concrete pour and wood form removal, break away exposed nails. 3. **Vertical Support Anchorage:** Screw threaded rod into PIP and tighten rod until fully seated. 4. **Seismic Restraint Anchorage:** Using the largest rod diameter that the insert will accept, insert threaded rod fastener into threads of steel barrel. Tighten rod until fully seated. Mount seismic bracket on exposed rod and flush with underside of deck. Install hex nut hand tight plus 1/2 turn minimum.

FIGURE 6—PIP INSTALLATION INSTRUCTIONS



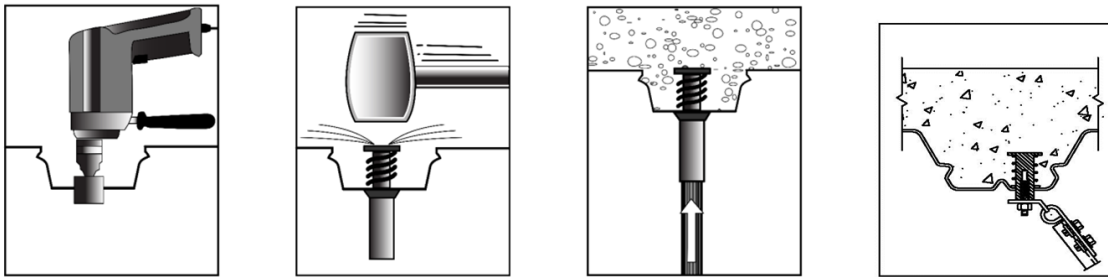
1. Position on wood form. Impact ISAT-PRPIP3812 (PRPIP3812) driving nails all the way into wood until plastic base sits flush and tight against form. 2. After concrete pour and wood form removal, break away exposed nails. 3. **Vertical Support Anchorage:** Push threaded rod into ISAT-PRPIP3812 (PRPIP3812) until the end of the threaded rod contacts the bottom of the steel barrel. Refer to [Figure 8](#) for the required threaded rod engagement into the ISAT-PRPIP3812 (PRPIP3812) insert for proper installation. When applicable, the optional engagement marker on the threaded rod will seat flush with the bottom of the insert indicating proper threaded rod engagement. 4. **Seismic Restraint Anchorage:** Using 1/2" diameter threaded rod, insert threaded rod until the end of the threaded rod contacts the bottom of the steel barrel. Optionally, the threaded rod can be tightened into the ISAT-PRPIP3812 insert. Mount seismic bracket on exposed rod and flush with underside of deck. Install hex nut hand tight plus 1/2 turn minimum.

FIGURE 6A—ISAT-PRPIP3812 INSTALLATION INSTRUCTIONS



1. Make hole in metal deck of following diameter using step-driller, hole saw or deck punch: SDI143812 (7/8" dia.), SDI381258 (1 3/16" dia.), SDI5834 (1 1/4" dia.). 2. Position SDI in hole. Impact head with sufficient force to compress spring and drive flared plastic fins completely thru hole. Screw attach SDI metal base plate to deck for additional stability (optional). 3. **Vertical Support Anchorage:** Insert threaded rod through finned plastic nozzle until contact with steel barrel. Engage SDI internal threads. Tighten rod until fully seated. 4. **Seismic Restraint Anchorage:** From beneath deck, trim away plastic nozzle flush with projecting 3/4" long metal barrel of SDI. Using the largest rod diameter that the insert will accept, insert threaded rod fastener into threads of steel barrel. Tighten rod until fully seated. Mount seismic bracket on exposed rod and up against insert barrel. Install hex nut hand tight plus 1/2 turn minimum.

FIGURE 7—SDI INSTALLATION INSTRUCTIONS



1. Make hole in metal deck of following diameter using step-driller, hole saw or deck punch: ISAT-PRSDI3812 (1 1/4" dia.). 2. Position ISAT-PRSDI3812 (PRSDI3812) in hole. Impact head with sufficient force to compress spring and drive flared plastic fins completely thru hole. Screw attach PRSDI metal base plate to deck for additional stability (optional). 3. **Vertical Support Anchorage:** Insert threaded rod through finned plastic nozzle until the end of the threaded rod contacts the bottom of the steel barrel. Refer to [Figure 8](#) for the required threaded rod engagement into the ISAT-PRSDI3812 (PRSDI3812) insert for proper installation. When applicable, the optional engagement marker on the threaded rod will seat flush with the bottom of the insert indicating proper threaded rod engagement. 4. **Seismic Restraint Anchorage:** From beneath deck, trim away plastic nozzle flush with projecting 3/4" long metal barrel of ISAT-PRSDI3812 (PRSDI3812). Using 1/2" diameter threaded rod, insert threaded rod until the end of the threaded rod contacts the bottom of the steel barrel, then fully tighten the threaded rod. Mount seismic bracket on exposed rod and up against insert barrel. Install hex nut hand tight plus 1/2 turn minimum.

FIGURE 7A—ISAT-PRSDI3812 INSTALLATION INSTRUCTIONS

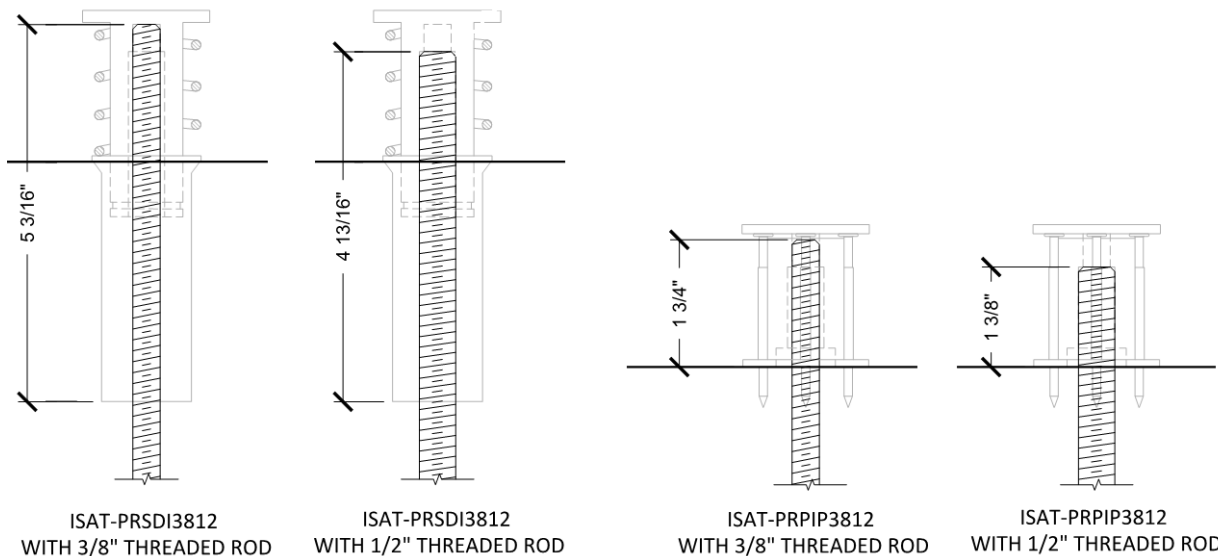


FIGURE 8 – REQUIRED THREADED ROD (ATR) ENGAGEMENT IN PUSH ROD INSERTS FOR PROPER INSTALLATION

**Given:**

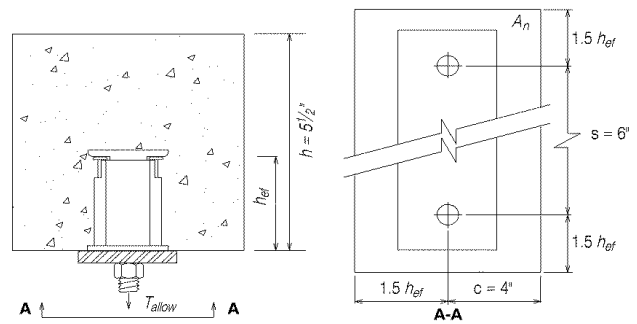
Two 1/2-inch ASTM A193 B7 threaded rods with PIP143812-2 under static tension load.

Normal weight concrete,  $f'_c = 3,000$  psi

No supplementary reinforcement (Condition B per ACI 318-14 17.3.3 c ACI 318-11 D.4.3 c)

Assume cracked concrete since no other information is available.

**Needed:** Using Allowable Stress Design (ASD) calculate the allowable tension load for this configuration.



Calculation per ACI 318-11 Appendix D, and ACI 318-14 Chapter 17 and this report.	ACI 318-11 Code Ref.	ACI 318-14 Code Ref.	Report Ref.
Step 1. Calculate steel capacity: $\phi N_{sa} = \phi A_{se,N} f_{uta} \times 2 = 0.65 \times 0.142 \text{ in.}^2 \times 125 \text{ ksi} \times 2 = 23,075 \text{ lb for (2) anchors}$ Not to exceed $\phi N_{sa,insert} = 0.65 \times 8415 \text{ lb} \times 2 = 5,470 \text{ lb} \times 2 = 10,940$ for (2) anchors			§4.1.2 <a href="#">Table 1</a>
Step 2. Calculate concrete breakout strength of anchor in tension: $N_{cbg} = \frac{A_{Nc}}{A_{Nco}} \psi_{ec,N} \psi_{ed,N} \psi_{c,N} \psi_{cp,N} N_b$	D.5.2.1	17.4.2.1	§ 4.1.3
Step 2a. Verify minimum member thickness, spacing, and edge distance: $h_{ef} = 1.874 \text{ in.} \leq 6 \text{ in.}$ – concrete clear cover = $6'' - 3/4'' = 5 1/4'' \therefore \text{OK}$ Spacing ( $s$ ) = $6 \text{ in.} > 4d_a = 4 \times 0.811 \text{ in.} = 3.2 \text{ in.} \therefore \text{OK}$ Edge distance = $4 \text{ in.} >$ cover distance required for the corresponding rebar. $\therefore \text{OK}$	D.8	17.7	<a href="#">Table 1</a> Fig. 3
Step 2b. Calculate $A_{Nco}$ and $A_{Nc}$ for the anchorage: $A_{Nco} = 9h_{ef}^2 = 9 \times (1.874 \text{ in.})^2 = 31.6 \text{ in.}^2$ No overlapping breakout cone: $A_{Nc} = 2A_{Nco}$	D.5.2.1	17.4.2.1	
Step 2c. Determine $\psi_{ec,N}$ : $e_N = 0 \therefore \psi_{ec,N} = 1.0$	D.5.2.4	17.4.2.4	
Step 2d. Calculate $N_b$ : $N_b = k_{cr} \lambda_a \sqrt{f'_c} h_{ef}^{1.5} = 24 \times 1.0 \times \sqrt{3,000} \times 1.875^{1.5} = 3,372 \text{ lb}$	D.5.2.2	17.4.2.2	
Step 2e. Calculate modification factor for edge distance: $c_{a,min} = 4 \text{ in.} > 1.5 h_{ef}$ , so $\psi_{ed,N} = 1.0$	D.5.2.5	17.4.2.5	
Step 2f. Calculate modification factor for cracked concrete: $\psi_{c,N} = 1.0$ (cracked concrete)	D.5.2.6	17.4.2.6	
Step 2g. Calculate modification factor for splitting: $\psi_{cp,N} = 1.0$ (for cast-in anchor)	D.5.2.7	17.4.2.7	
Step 2h. Calculate $\phi N_{cbg}$ : $\phi N_{cbg} = 0.7 \times \frac{63.2}{31.6} \times 1.0 \times 1.0 \times 1.0 \times 3,372 = 4,721 \text{ lb}$	D.5.2.1	17.4.2.1	§ 4.1.3
Step 3. Check face-side breakout strength: $h_{ef} < 2.5 c_{a1}$ , no check required.	D.5.4	17.4.4	§ 4.1.4
Step 4. Controlling strength: $\phi N_{cbg} = 4721 \text{ lb} < \phi N_{sa} \therefore \phi N_{cbg}$ controls			
Step 5. To convert to ASD, assume $U = 1.2D + 1.6L$ : $T_{ASD} = \frac{4,721}{1.48} = 3,190 \text{ lb}$			§ 4.2

FIGURE 9—EXAMPLE CALCULATION

**DIVISION: 03 00 00—CONCRETE****Section: 03 15 19—Cast-in Concrete Anchors****Section: 03 16 00—Concrete Anchors****REPORT HOLDER:****TOMARCO CONTRACTOR SPECIALTIES, INC. dba ISAT dba CEAS****EVALUATION SUBJECT:****ISAT “BLUE BANGER HANGER” HEADED, CAST-IN-PLACE DECK INSERTS: PIP POURED-IN-PLACE AND SDI STEEL DECK INSERTS IN CRACKED AND UNCRACKED CONCRETE; ISAT “PUSH ROD HANGERS” (CEAS “PUSH ROD”) HEADED, CAST-IN-PLACE DECK INSERTS: ISAT-PRPIP3812 (PRPIP3812) PUSH ROD POURED-IN-PLACE AND ISAT-PRSDI3812 (PRSDI3812) PUSH ROD STEEL DECK INSERTS IN CRACKED AND UNCRACKED CONCRETE****1.0 REPORT PURPOSE AND SCOPE****Purpose:**

The purpose of this evaluation report supplement is to indicate that the ISAT “Blue Banger Hanger” PIP, SDI, ISAT-PRPIP3812, and ISAT-PRSDI3812 Headed Cast-In Specialty Inserts in cracked and uncracked concrete, described in ICC-ES evaluation report [ESR-3599](#), have also been evaluated for compliance with the codes noted below as adopted by the Los Angeles Department of Building and Safety (LADBS).

**Applicable code editions:**

- 2020 City of Los Angeles Building Code ([LABC](#))
- 2020 City of Los Angeles Residential Code ([LARC](#))

**2.0 CONCLUSIONS**

The ISAT “Blue Banger Hanger” PIP, SDI, ISAT-PRPIP3812, and ISAT-PRSDI3812 Headed Cast-In Specialty Inserts in cracked and uncracked concrete, described in Sections 2.0 through 7.0 of the evaluation report [ESR-3599](#), comply with LABC Chapter 19, and the LARC, and are subject to the conditions of use described in this supplement.

**3.0 CONDITIONS OF USE**

The ISAT “Blue Banger Hanger” PIP, SDI, ISAT-PRPIP3812, and ISAT-PRSDI3812 Headed Cast-In Specialty Inserts described in this evaluation report supplement must comply with all of the following conditions:

- All applicable sections in the evaluation report [ESR-3599](#).
- The design, installation, conditions of use and identification of the ISAT “Blue Banger Hanger” PIP, SDI, ISAT-PRPIP3812, and ISAT-PRSDI3812 Headed Cast-In Specialty Inserts are in accordance with the 2018 *International Building Code*® (IBC) provisions noted in the evaluation report [ESR-3599](#).
- The design, installation and inspection are in accordance with additional requirements of LABC Chapters 16 and 17 and the City of Los Angeles Information Bulletin P/BC 2020-092, as applicable.
- Under the LARC, an engineered design in accordance with LARC Section R301.1.3 must be submitted.
- The allowable and strength design values listed in the evaluation report and tables are for the connection of the headed cast-in specialty inserts to the concrete. The connection between the headed cast-in specialty inserts and the connected members shall be checked for capacity (which may govern).

This supplement expires concurrently with the evaluation report, reissued November 2024.



**DIVISION:03 00 00—CONCRETE****Section: 03 15 19—Cast-in Concrete Anchors****Section: 03 16 00—Concrete Anchors****REPORT HOLDER:****TOMARCO CONTRACTOR SPECIALTIES, INC. dba ISAT dba CEAS****EVALUATION SUBJECT:****ISAT “BLUE BANGER HANGER” HEADED, CAST-IN-PLACE DECK INSERTS: PIP Poured-in-place AND SDI STEEL DECK INSERTS IN CRACKED AND UNCRACKED CONCRETE; ISAT “PUSH ROD HANGERS” (CEAS “PUSH ROD”) HEADED, CAST-IN-PLACE DECK INSERTS: ISAT-PRPIP3812 (PRPIP3812) PUSH ROD Poured-in-place AND ISAT-PRSDI3812 (PRSDI3812) PUSH ROD STEEL DECK INSERTS IN CRACKED AND UNCRACKED CONCRETE****1.0 REPORT PURPOSE AND SCOPE****Purpose:**

The purpose of this evaluation report supplement is to indicate that ISAT inserts, described in ICC-ES evaluation report ESR-3599, has also been evaluated for compliance with the codes noted below.

**Applicable code editions:**

- 2019 *California Building Code*® (CBC)

For evaluation of applicable chapters adopted by the California Office of Statewide Health Planning and Development (OSHPD) AKA: California Department of Health Care and Information (HCAI) and the Division of State Architect (DSA), see Sections 2.1.1 and 2.1.2 below.

- 2019 *California Residential Code*® (CRC)

**2.0 CONCLUSIONS****2.1 CBC:**

The ISAT inserts, described in Sections 2.0 through 7.0 of the evaluation report ESR-3599, complies with CBC Chapter 19, provided the design and installation are in accordance with the 2018 *International Building Code*® (IBC) provisions noted in the evaluation report and the additional requirements of CBC Chapters 16, 17 and 19 as applicable.

**2.1.1 OSHPD:**

The applicable OSHPD Sections and Chapters of the CBC are beyond the scope of this supplement

**2.1.2 DSA:**

The applicable DSA Sections and Chapters of the CBC are beyond the scope of this supplement.

**2.2 CRC:**

The ISAT inserts, described in Sections 2.0 through 7.0 of the evaluation report ESR-3599, complies with CRC Chapter 3, provided the design and installation are in accordance with the 2018 *International Residential Code*® (IRC) provisions noted in the evaluation report and the additional requirements of CRC Chapter 3, as applicable.

This supplement expires concurrently with the evaluation report, reissued November 2024.